

2024

DEAERATORS AND DIRT SEPARATORS CATALOG

VIRA[®]

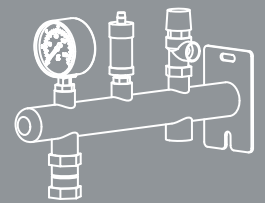

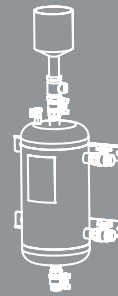
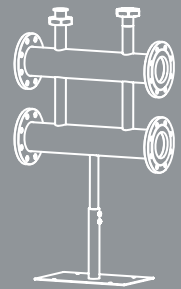
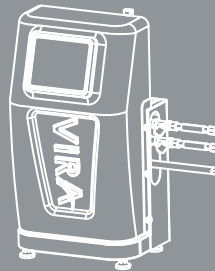
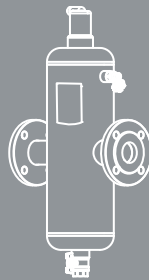
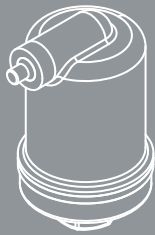

ALASKA (USA)

CANADA

(USA)
UNITED STATES OF AMERICA

MEXICO

VENEZUELA
COLOMBIA
ECUADOR
PERU
BOLIVIA
PARAGUAY
URUGUAY
CHILE
ARGENTINA

BRAZIL

IRELAND
UNITED KINGDOM
FRANCE

PORTUGAL
SPAIN

MOROCCO
ALGERIA

MAURITANIA
MALI

BURKINA FASO
GUINEA-BISSAU
GUINEA
SIERRA LEONE
LIBERIA
IVORY COAST
GHANA
BENIN



AIR VENT



SS

ST

VIRADEG



V3 - V6 - V9

VIRAVENT



SV-D-Y

SV-D-D

SV-F



VIRACLEAN



SD-F

SD-F-M

SD-F-T

VIRACLEAN

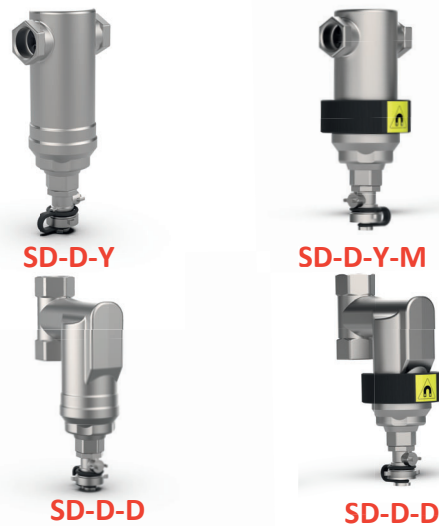

SD-D-Y

SD-D-Y-M

SD-D-D

SD-D-D-M

VIRAJAC



VIRADOSING



VIRABALANCE

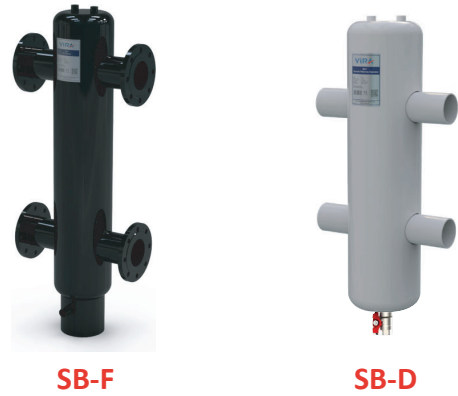

VIRAPLUS



VIRAFIX



CONTENTS

AIR IN HEATING AND COOLING SYSTEMS	7
DIRT IN HEATING AND COOLING SYSTEMS	9
VIRADEG VACUUM DEGASSER	10
V-FORCE MAGNETIC FILTER	12
VIRATOP / VIRASOLAR	13
VIRAVENT	15
VIRACLEAN	19
VIRAPLUS	23
VIRAFIX	26
VIRABALANCE	29
CUSTOMIZED MODELS / OEM PRODUCTIONS	32
VIRAJAC	33
CHEMICAL DOSING POT	35
FULL FLOW MAGNETIC FILTER	38
MAGNETIC FILTER	39
VIRACONSOLE	40
VIRAEXPAN	41
BUFFER-TANKS	43
EXPANSION JOINT	44
MULTIZONE MANIFOLDS	45
MANIFOLDS	46
SIZING	47
PRESSURE DROP	48

AIR IN HEATING AND COOLING SYSTEMS

The Problems Caused by Air

Air in heating and cooling systems causes the following problems:

- Noise in radiators, heat exchangers, pipes and pumps,
- Rapid wear and tear of heat exchangers, controllers, shut-off valves and pumps,
- Insufficient heat emission or cooling efficiency, reduced heat transfer,
- Increased energy consumption,
- Needing to deaerate by hand,
- Higher maintenance costs,
- Corrosion

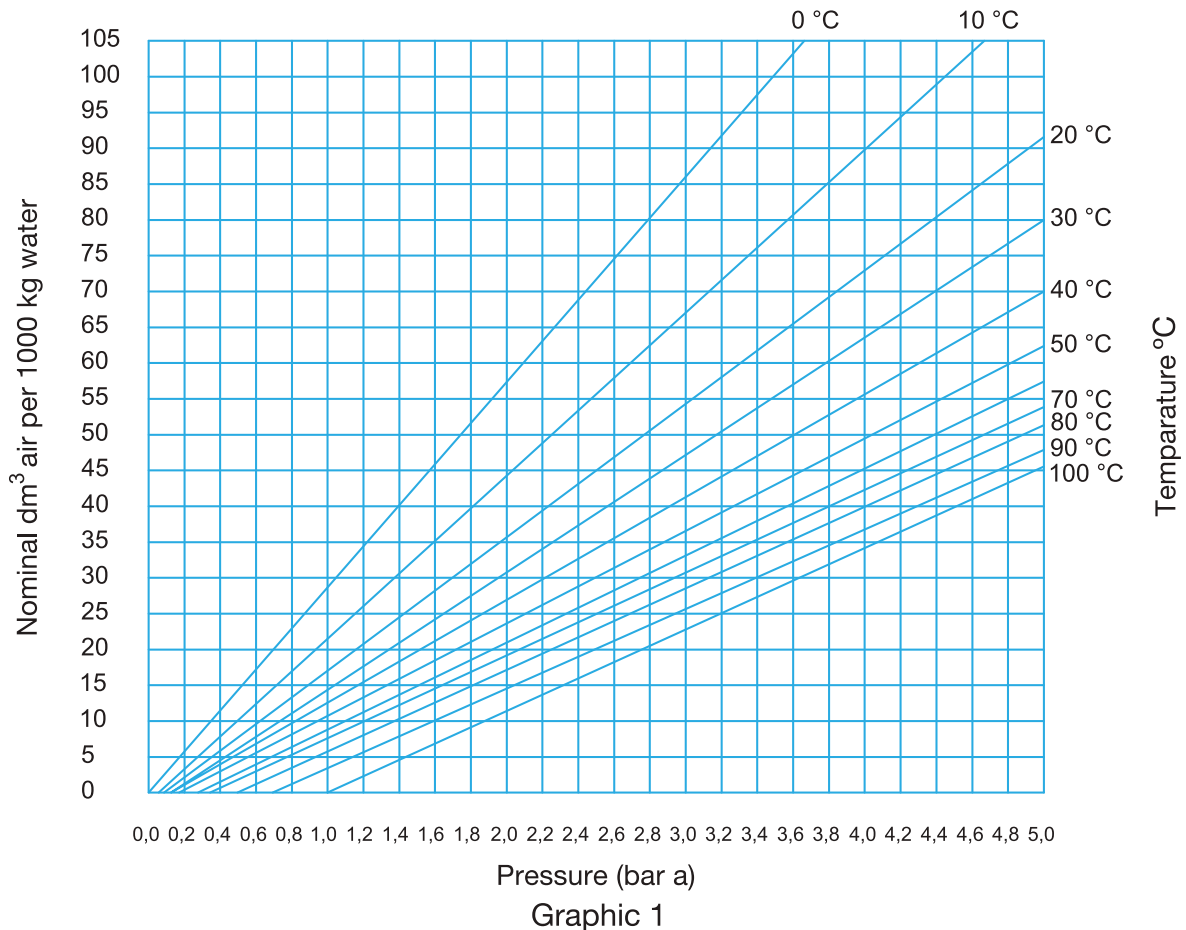

Occurring and Source of Air in System

- Air is present before filling the system and trapped in the system when filled.
- Air is entrained in mains water when filling the system.
- Air dissolved in water is released when the temperature rises or the pressure falls during system runs. (Graphic 1)

Air in Heating System

The amount of air dissolved in water depends on both temperature and pressure. Air dissolved in water is released when the temperature rises or the pressure falls. (Graphic1) The release of microbubbles takes place continuously in the boiler and in any device operating under cavitation conditions. When high temperatures occur at the combustion chamber wall of the boiler, small air bubbles are released from the air containing water. (Figure 1) Microbubbles should be removed as soon as they leave the boiler.

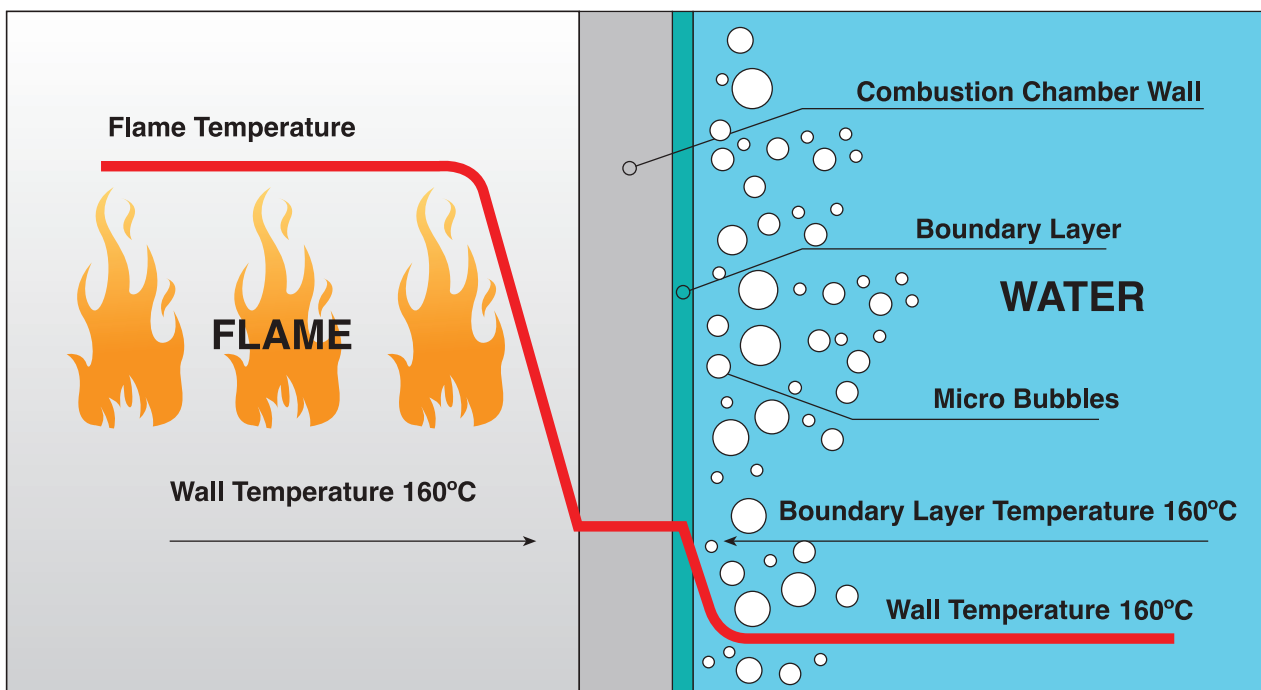

Air in Cooling System

Pressure has the greatest effect on the formation of air bubbles in a cooling system.

As the temperature of the water in the coil decreases, some of the air bubbles will dissolve in the water. To prevent air bubbles from causing pump damage due to cavitation, air bubbles should be vented upstream of the pump.



DIRT IN HEATING AND COOLING SYSTEMS

The Problems Caused by Dirt

Dirt in heating and cooling systems causes the following problems:

- Increased system noise,
- Heat exchangers, boilers, and radiators can become clogged. This restricts the flow of water and reduces heat transfer.
- Clogging of strainers, resulting in increased pressure drop and hence additional pump costs or loss of capacity,
- The seals on the pump will be exposed to the abrasive effect of the particles in the water and will wear out more quickly.
- Low-velocity pipework (such as underfloor heating) can accumulate debris. This reduces the heat transfer surface,
- Higher maintenance costs,
- The build-up of sludge and dirt in a system will have a detrimental effect on the efficiency of the system.



Accumulation and Source of Dirt in the System

- Dirt enters the system during production (e.g. sand, pipe cuttings and welding slag).
- Once in operation, there will also be an accumulation of scale and particles from corrosion the dissolved oxygen is the cause of corrosion.

The reaction between iron, water and oxygen will forms magnetite, and if oxygen is then present, the magnetite is converted to hematite.

VIRADEG VACUUM DEGASSER

Description

Vacuum degassing is the process of removing dissolved gas from a liquid solution by reducing the pressure inside a vessel containing the solution. The reduced pressure in the vessel causes the gas to become less soluble and separate from the liquefied material. When vacuum degassing is complete, the gas is removed from the vessel and the pressure returns to normal.

ViraDeg vacuum degassers are installed in a bypass in the main flow of heating and cooling systems. Part of the system fluid is temporarily placed under vacuum. Gases dissolved in the fluid are released, separated and removed from the system. When the deaerator fluid is reintroduced into the system, it can absorb further free air pockets from the circuit. Air-free installation ensures optimum system performance and also significantly reduces commissioning times. As well as optimizing system efficiency, all standard ViraDeg models save additional energy thanks to the integrated SmartSwitch. This device ensures that the deaerator only operates when necessary.



ViraDeg V3



ViraDeg V6

Features

- System Voltage : 220, 230 V \pm 10% / 50 Hz
- Connection Sizes : 1/2" - 3/4"
- Operating Temp. : 0-90 °C
- Ambient Temp. : 0-40 °C
- Feature : Standby Mode



Dimensions

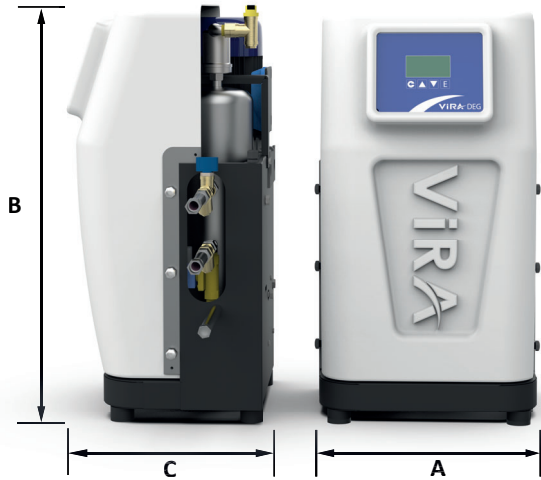

	A (mm)	B (mm)	C (mm)
V3	435	770	365
V3-R	435	770	365
V6	435	770	390
V6-R	435	770	390

Benefits

- Removes all gases, free air, microbubbles and dissolved gases.
- The absorbent liquid also helps to remove trapped bubbles.
- Easy to install, which greatly reduces commissioning and handover.
- Energy efficient with the lowest possible gas consumption.
- Concentration thanks to SmartSwitch.
- Degassed (re)filling and sustained pressure.
- Warns of excessive (re-)filling.
- An extensive range for a wide variety of systems.
- Can be teamed with all common expansion systems.

Functional Description

The main purpose of the vacuum deaerator is to release the dissolved gases circulating in Closed-loop heating and cooling systems and to REMOVE them from the system.

ViraDeg vacuum deaerator is connected to the system as a by-pass and after pressurising the water it has taken from the system, it applies a vacuum, to release the dissolved gasses in the water. The released gases are vented via air vents. Vacuum degassing is the technique of removing dissolved gas from a liquid solution by reducing the pressure in a vessel containing the solution.



V-FORCE MAGNETIC FILTER

Dirt / Sediment Separator

V-FORCE magnetic separators are designed to be the most effective way of separating magnetic particles circulating in heating and cooling systems. Thanks to the powerful magnets inside, the magnetic particles circulating with the water are captured by the magnetic field created in the V-FORCE and will be prevented from circulating in the system.

Installer Benefits

- Available for DN50 - DN200 pipe dimensions with PN16 flanges
- Supplied with EPDM flange and lid gaskets for robust sealing at high temperatures
- Individual magnet assemblies can be lifted independently for ease of cleaning & maintenance, removing the need to disassemble and replace the filter lid during servicing.
- Installers do not need additional airvent to release microbubbles from the system.

Technical Specifications

- PN16, supplied with EPDM gaskets
- Material: Carbon Steel / Stainless steel
- Drain point: 1" BSP hole,
- Maximum working pressure: 10 bar
- Maximum working temperature: 100°C
- Product side seal: EPDM
- Magnet: Neodymium
- ViraTop high capacity nickel-coated air vent



VForce-D VForce-D

Customization

- Vira, which is an expert manufacturer in the field of filtration, can have a custom design for any of its products.

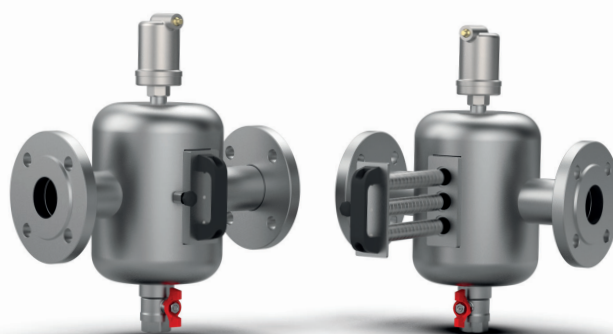

VForce-Y

VForce-Y

VIRATOP / VIRASOLAR

Description

The ViraTop reliably discharges air and other gases from the system. The purging of free gas bubbles is necessary to enable the heat transfer medium to circulate in liquid-filled system circuits. This purging can either be done manually or, better still, automatically operated devices. In the case of the automatic variant, a key requirement for the relevant fitting is sustained reliability and, above all, freedom from leaks. The ViraTop has been developed with this in mind.

It automatically purges air and other gases from the system into the surrounding atmosphere. This enables problem-free filling and draining operations when filling or refilling heating, solar or cooling systems, for example. The ViraTop discharges the air that has collected at high points or specifically designated collection points quickly and reliably into the atmosphere.



ViraTop SS

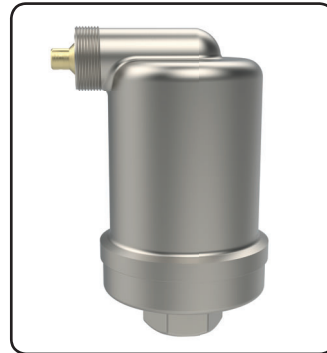

ViraTop ST

Technical data for the ViraTop

- Housing made of brass
- For vertical installation
- With system connection G 1/2 and a connecting thread G 1/2 at the vent valve
- Application limits: 110 or 160 °C and 10 bar overpressure

Fields of application

- Venting during billing operations after draining or new construction
- In-service venting of things, high points, and air collection points
- Automatic pressurization during draining operations
- High venting capacity
- Solid brass capacity
- Designed for simple pressurization and venting of the system with consistently high reliability
- Reliable operation, even if the medium is dirty
- Range of products for different temperatures and applications

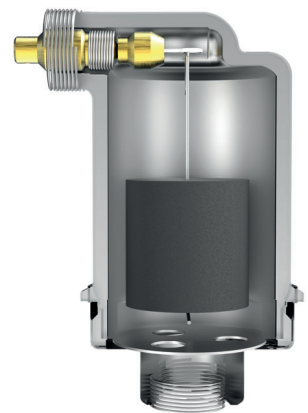

Functional description

The air collection chamber of the ViraTop contains a float-controlled vent valve. If the freely suspended float loses buoyancy due to the air that has accumulated in the collection chamber, it sinks and in the process opens the vent valve. The float has enough space to move freely even if there are dirt deposits in the air collection chamber. The special design of the vent valve ensures smooth operation even under difficult conditions.

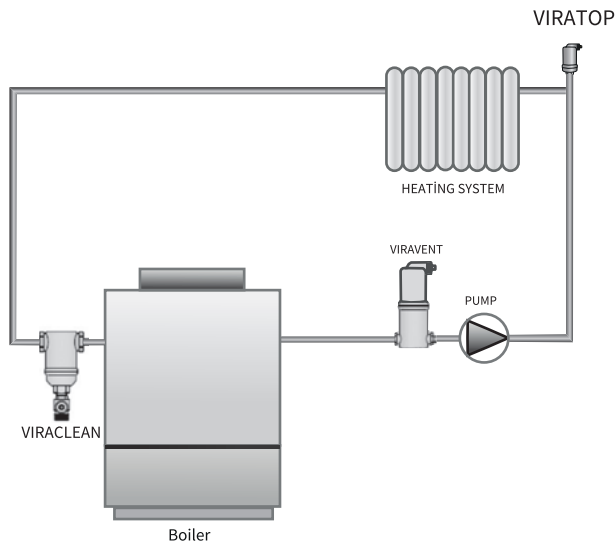

Benefits

- Effectively evacuates gases and microbubbles freely circulating in the installation
- Prevents wear and erosion in heat exchangers, valves and pumps
- Prevents corrosion
- Provides automatic air evacuation instead of manually removing air from the system
- Prevents noise in radiators, heat exchangers, pipes and pumps
- Helps to provide high heat transfer.

Dimensions

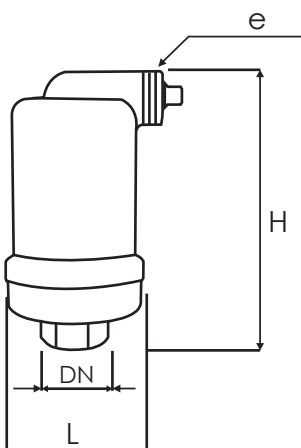

	Connection	H (mm)	h (mm)	L (mm)	e (inch)	Weights (kg)
ST	1/2"	106,18	-	59,9	1/2"	0,595
SS	1/2"	106,18	-	59,9	1/2"	0,595

VIRAVENT

Fields of application

- Venting during billing operations after draining or new construction
- In-service venting of things, high points, and air collection points
- Automatic pressurization during draining operations
- High venting capacity
- Solid brass design
- Designed for simple pressurization and venting of the system with consistently high reliability
- Reliable operation, even if the medium is dirty
- Range of products for different temperatures and applications



SV-F

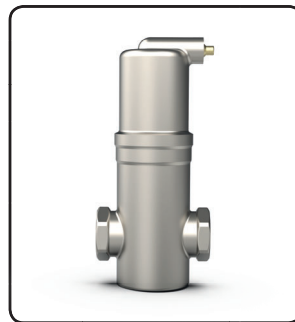

SV-D-Y



SV-D-D

Description

The Viravent is a high-efficiency in-line air separator suitable for use on heating and chilled systems. In sealed heating systems free and dissolved air causes a number of problems. Micro-bubbles form on the pump suction as a direct result of localized pressure drop. This directly affects the liquid displacement of rotary pumps, reducing the flow capacity and therefore the efficiency of the system. The presence of micro-bubbles and dissolved gas can reduce the liquid displacement of a pump by 10 to 45%. Heat will also allow dissolved gasses to be drawn out of the solution, following Henry's law, placement of this equipment is ntee effective operation. Effective removal of free air is essential for increasing the operational life of the system as a whole.

Features

Body	: Carbon Steel - ST37 / Nickel Coated
Size	: DN 50 - 600
Max. Work.Temp.	: 110 °C
Max. Work. Pressure	: 10 Bar
Product Code	: SV

Benefits

- Removes all circulating air and micro bubbles effectively.
- Removes trapped air when installed at the correct location.
- Greatly reduces the need for manual venting.
- Constant low-pressure drop.
- No unnecessary shutdown.
- Connection diameters from 3/4" to DN600 and above.
- A complete range, suitable for various pressures and temperatures.
- Exceptional guarantee.



Where to Install for better performance?

The Viravent, air must be installed at the hottest point in the system. For a heating installation, this is in the flow from the boiler. Microbubbles are released at the hottest spot in an installation. This release of gas is determined by the solubility of gases in water. The solubility reduces with an increase in temperature. In case of a decrease in pressure, Henry's law implies further solubility. In simple terms, the air is released from the water as the temperature increases or the pressure decreases.



Installations

Viravent units must be installed at the hottest part of the system for optimum performance. The static head must not exceed 15m for heating system and 5m for cooling system.

The efficiency of the unit will be reduced if;

- The static head is exceeded.
- The maximum flow velocity of 3m/s is exceeded.

In heating systems the deaerator should be in the flow, preferably at the highest temperature (next to the heat source) and low pressure if possible. Viravent, Deaerator should be installed after the boiler and on the pump suction side, as these are the points where the formation of microbubbles is greatest. In chilled water systems, the unit must be located in the return close to the chiller.

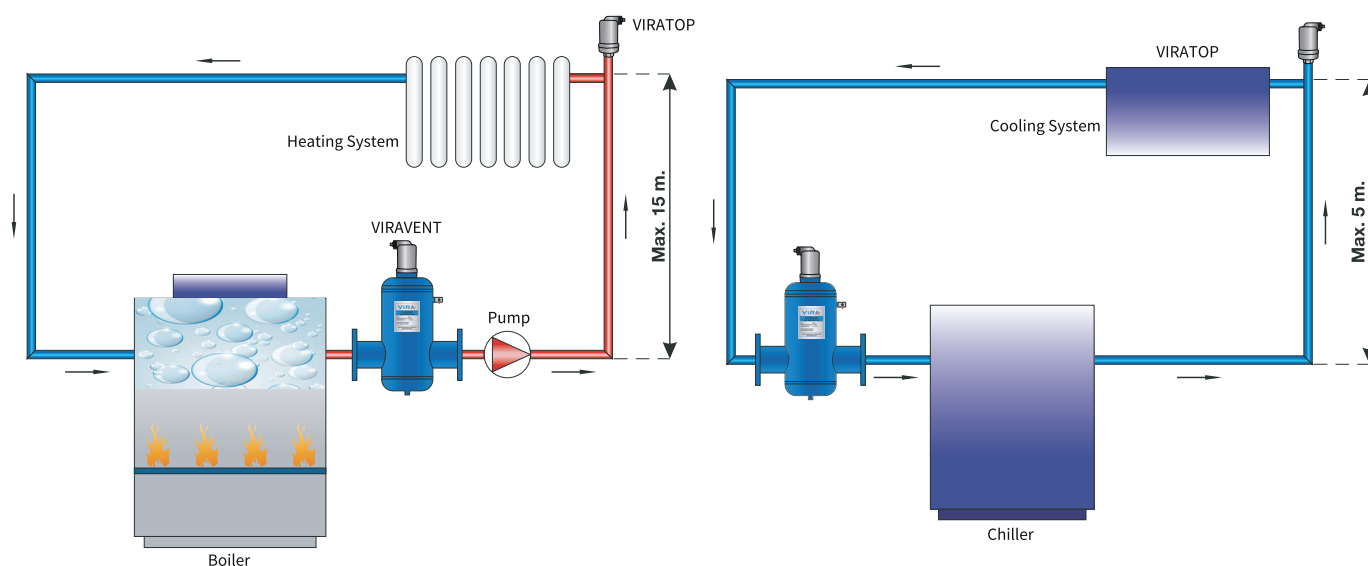

Advantages

- Greatly reduced commissioning times after initial fill, no more venting required.
- Optimum heat transfer.
- Increased component life.
- No pump cavitation.
- Quiet operation.
- Two-year guarantee.

Dimensions

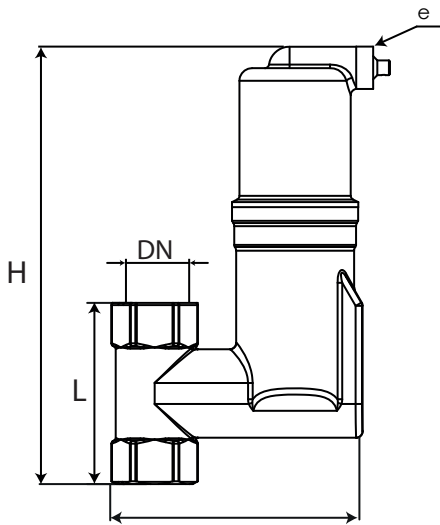

SV-D-D

	Connection	H (mm)	L (mm)	h (mm)	e (inch)	Weights (kg)	Max.Flow (L/s)	Max.Flow (m ³ /h)
SV-D-D	1"	208	86	165,2	1"	1,870	0,86	3,10

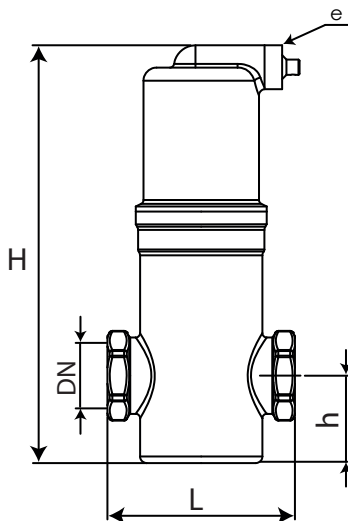

SV-D-Y

	Connection	H (mm)	L (mm)	h (mm)	e (inch)	Weights (kg)	Max.Flow (L/s)	Max.Flow (m ³ /h)
SV-D-Y	3/4"	191,2	86	25	1/2"	1,010	0,74	2,65
SV-D-Y	1"	191	85	40	1/2"	1,053	0,86	3,10
SV-D-Y	1-1/4"	196	85	40	1/2"	1,150	1,28	4,60
SV-D-Y	1-1/2"	204,5	93,5	44,5	1/2"	1,260	1,94	7,00
SV-D-Y	2"	211	98	44,5	1/2"	1,410	3,40	12,25

Dimensions

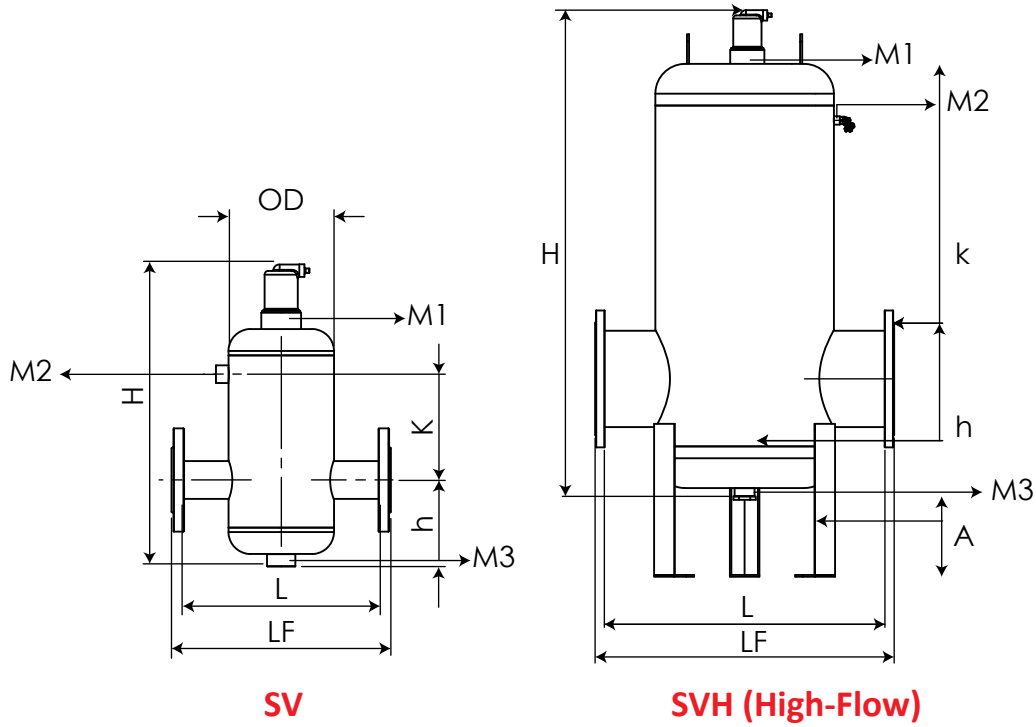

	Connection DN	OD (mm)	L (mm)	LF (mm)	H (mm)	h (mm)	Standart; Nom. 1,5 m/s				Hi-flow; nom. 3 m/s				M1	M2	M3		
							nom. = 1,5 m/s				max. = 3 m/s								
							Max.Flow (L/s)	Max.Flow (m ³ /h)	Max.Flow (kPa)	Leg A (mm)	H (mm)	h (mm)	Max.Flow (L/s)	Max.Flow (m ³ /h)	Max.Flow (kPa)	Leg A (mm)			
SV	50	168,3	330	350	482	138	3,3	12	3		650	150	5,8	21	11,8		1 3/4"	1/2"	1"
SV	65	168,3	330	350	482	138	6,3	22,5	2,7		650	150	10,0	36	11,6		1 3/4"	1/2"	1"
SV	80	219,1	450	470	607	177	8,3	30	2,9		730	200	15,0	54	12,4		1 3/4"	1/2"	1"
SV	100	219,1	455	475	607	177	12,5	45	3,7		730	200	23,3	84	14,6		1 3/4"	1/2"	1"
SV	125	323,9	615	635	797	267	20,8	75	4,2		1067	250	36,7	132	16,8		1 3/4"	1/2"	1"
SV	150	323,9	615	635	797	267	31,3	112,5	4,9		1067	250	52,8	190	19,4		1 3/4"	1/2"	1"
SV	200	400	745	775	997	297	52,1	187,5	5,8		1317	300	94,2	339	23,1		1 3/4"	1/2"	1"
SV	250	500	860	890	1237	357	83,3	300	6,9		1677	360	146,9	529	27,7		1 3/4"	1/2"	2"
SV	300	600	975	1005	1557	395	114,6	412,5	7,7		2032	410	211,9	763	31	270	1 3/4"	1/2"	2"
SV	350	700	1098	1128	1940	430	143,8	517,5		270	2430	543	288,3	1038		270	1 3/4"	1/2"	2"
SV	400	800	1194	1226	2170	480	188,3	678		270	2707	609	376,7	1356		270	1 3/4"	1/2"	2"
SV	450	900	1300	1330	2388	540	238,3	858		270	3000	650	476,7	1716		270	1 3/4"	1/2"	2"
SV	500	1000	1400	1430	2680	590	294,2	1059		270	3220	703	588,6	2119		270	1 3/4"	1/2"	2"
SV	600	1200	1600	1630	3020	680	423,8	1525,5		270	3870	820	847,8	3052		270	1 3/4"	1/2"	2"

VIRACLEAN

Description

The life and the efficiency of a heating or cooling system are greatly dependent on clean system water. Dirt can cause many problems such as increased component wear and frequent break-downs. Corrosion, pump wear, and reduced efficiency result in increased maintenance, unnecessarily high costs, and dissatisfied customers. Traditionally strainers or filters are fitted to overcome dirt problems. However, these require frequent maintenance and if not cleaned on a regular basis cause increased pressure drops and eventually blockages.



SD-D-Y



SD-D-Y-M



SD-D-D



SD-D-D-M



SD-F



SD-F-M



SD-F-T

Features

Body	: Carbon Steel - ST37 / Nickel Coated
Size	: DN 50-600
Max. Work.Temp.	: 110 °C
Max. Work. Pressure	: 10 Bar
Product Code	: SD

Benefits

- Very small particles, from 5 μm (= 0.005 mm) and up are separated and removed.
- Dirt can be drained while the system is in operation.
- No shut-off valves or bypass required.
- Constant low-pressure drop.
- Maintenance only takes a few seconds and is not a dirty job.
- Compared to a filter solution.
- No unnecessary shutdown.
- Connection diameters from $\frac{3}{4}$ " to DN 600 and above.
- A complete range, suitable for various pressures and temperatures.



Installations

Dirt Separators should always be installed before equipment (ie. boilers, chillers, control valves, pumps, etc.) That needs protection from dirt, sludge, etc. In heating systems, this should be in return. In chilled water systems, the unit must be located in the return close to the chiller.

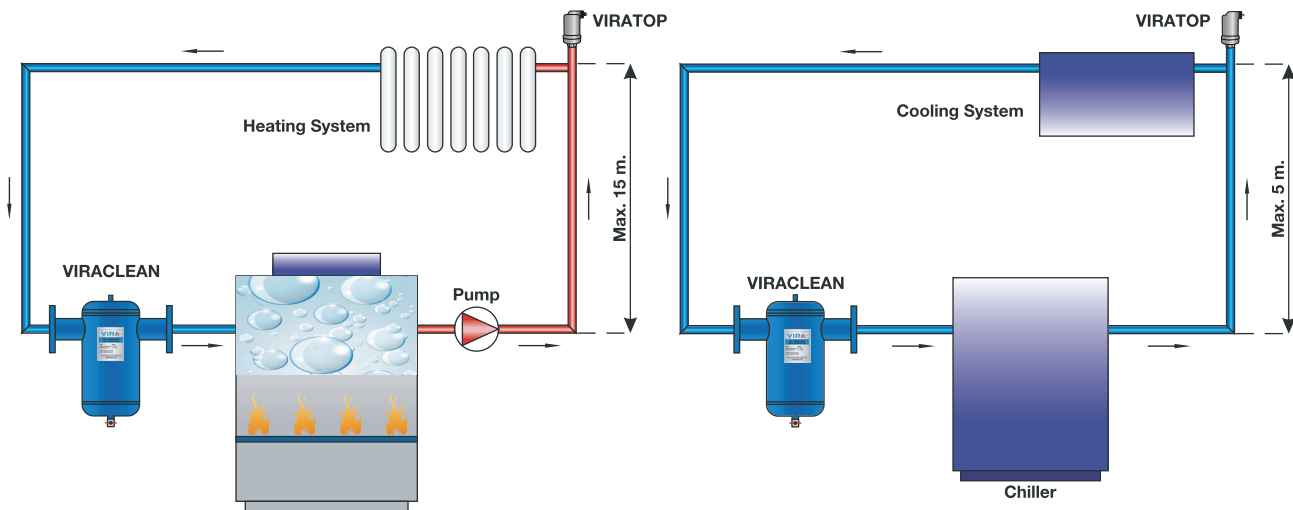

The Solution...

A system totally without dirt is possible.

There is a unique device that will remove all dirt down to the smallest particle. It works continuously and is maintenance-free.

In heating and air conditioning control systems, the circulation of water containing impurities may result in rapid wear and damage to components such as pumps and control valves. It also causes blockages in heat exchangers, heating elements, and pipes, resulting in lower thermal efficiency within the system.

The dirt separator removes these dirt particles, collecting them in a large collection chamber from which they can be flushed even while the system is in operation. This device is capable of efficiently removing even the smallest particles, with very low head loss.

The ViraClean® magnetic dirt separator removes both ferrous and non-ferrous impurities continuously, featuring powerful removable magnets that remove up to 100% of the ferrous impurities, including magnetite, that can form in a hydronic system.

Advantages

- Dirt can be used while the system is fully operational.
- All dirt can be removed in one central location in the plant room with virtually no maintenance and no replacement filters.
- No by-pass or isolating valves required minimum pressure drop, always constant can not block the flow.
- In addition to conventional dirt, it also removes microscopic dirt particles.
- Three-year guarantee.

Dimensions

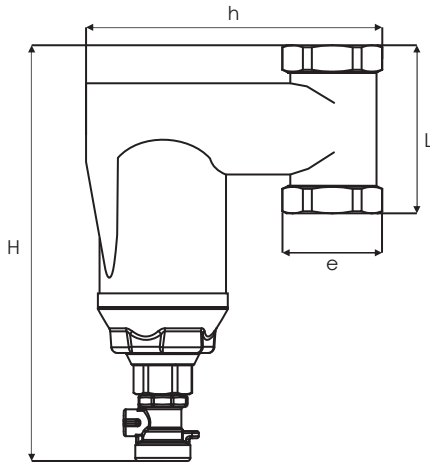

SD-D-D

	Connection	H (mm)	L (mm)	h (mm)	e (inch)	Weights (kg)	Max.Flow (L/s)	Max.Flow (m ³ /h)
SD-D-D	1"	214,4	86	188,45	1"	1,790	0,86	3,10

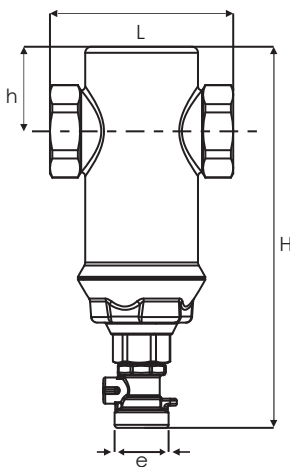

SD-D-Y

	Connection	H (mm)	L (mm)	h (mm)	e (inch)	Weights (kg)	Max.Flow (L/s)	Max.Flow (m ³ /h)
SD-D-Y	3/4"	194	85,8	25	1/2"	1,010	0,74	2,65
SD-D-Y	1"	194	85,8	40	1/2"	1,053	0,86	3,10
SD-D-Y	1-1/4"	199	85	40	1/2"	1,150	1,28	4,60
SD-D-Y	1-1/2"	207,5	93,5	44,5	1/2"	1,260	1,94	7,00
SD-D-Y	2"	214	98	44,5	1/2"	1,410	3,40	12,25

Dimensions

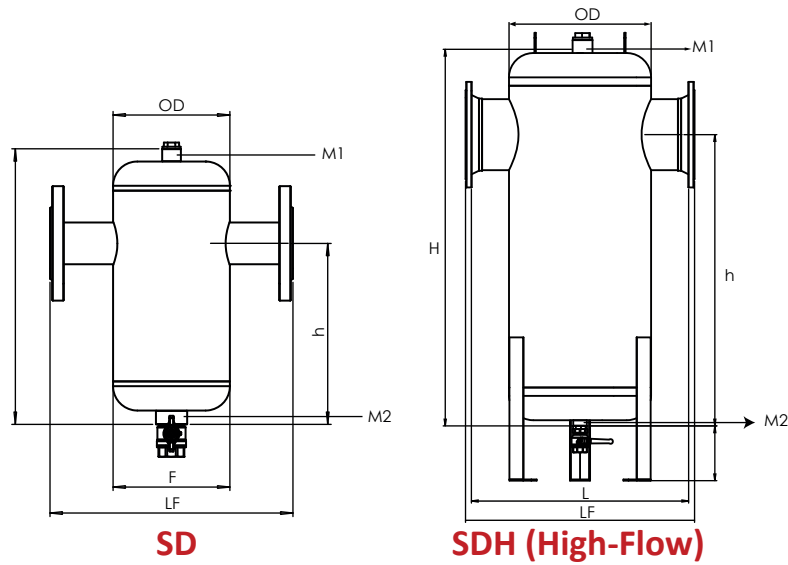

		Standart; Nom. 1,5 m/s								Hi-flow; nom. 3 m/s								
		nom. = 1,5 m/s								max. = 3 m/s								
Connection DN	OD (mm)	L (mm)	LF (mm)	H (mm)	h (mm)	Max.Flow (L/s)	Max.Flow (m3/h)	Max.Flow (kPa)	Leg A (mm)	H (mm)	h (mm)	Max.Flow (L/s)	Max.Flow (m3/h)	Max.Flow (kPa)	Leg A (mm)	M1	M2	
SD	50	168,3	330	350	398	261	3,3	12	3		565	417	5,8	21	11,8		1/2"	1"
SD	65	168,3	330	350	398	261	6,3	22,5	2,7		565	417	10,0	36	11,6		1/2"	1"
SD	80	219,1	450	470	522	347	8,3	30	2,9		645	447	15,0	54	12,4		1/2"	1"
SD	100	219,1	455	475	522	347	12,5	45	3,7		645	447	23,3	84	14,6		1/2"	1"
SD	125	323,9	615	635	712	447	20,8	75	4,2		982	734	36,7	132	16,8		1/2"	1"
SD	150	323,9	615	635	712	447	31,3	11,5	4,9		982	734	52,8	190	19,4		1/2"	1"
SD	200	400	745	775	911	617	52,1	187,5	5,8		1233	934	94,2	339	23,1		1/2"	1"
SD	250	500	860	890	1152	804	83,3	300	6,9		1592	1242	146,9	529	27,7		1/2"	2"
SD	300	600	975	1005	1472	1087	114,6	412,5	7,7		1947	1547	211,9	763	31		1/2"	2"
SD	350	700	1098	1128	1855	1434	143,8	517,5		270	2345	1812	288,3	1038		270	1/2"	2"
SD	400	800	1194	1226	2085	1614	188,3	678		270	2622	2023	376,7	1356		270	1/2"	2"
SD	450	900	1300	1330	2303	1773	238,3	858		270	2915	2275	476,7	1716		270	1/2"	2"
SD	500	1000	1400	1430	2595	2015	294,2	1059		270	3135	2442	588,6	2119		270	1/2"	2"
SD	600	1200	1600	1630	2935	2265	423,8	1525,5		270	3785	2975	847,8	3052		270	1/2"	2"

Description

Air and dirt-free system water through a single unit.

ViraPlus combined dirt and air separators can be used in place of individual deaerators and dirt separators. These combined units are highly efficient and extremely cost-effective and are becoming becoming the preferred standard option throughout the industry. In heating systems, the units should be installed in the flow loop, situated immediately after the boiler and before the pump. In a chilled water system, the unit must be located in the return loop close to the chiller.



SC-F



SC-F-M



SC-F-T

Features

Body	: Carbon Steel - ST37/Nickel Coated
Size	: DN 50 - 600
Max. Work.Temp.	: 110 °C
Max. Work. Pressure:	10 Bar
Product Code	: SC

Benefits

- Very small particles, from 5 μm (= 0.005 mm) are separated and removed
- Removes circulating air and micro bubbles effectively
- Dirt can be discharged while the system is in operation
- Constant low pressure drop
- Exceptional guarantee

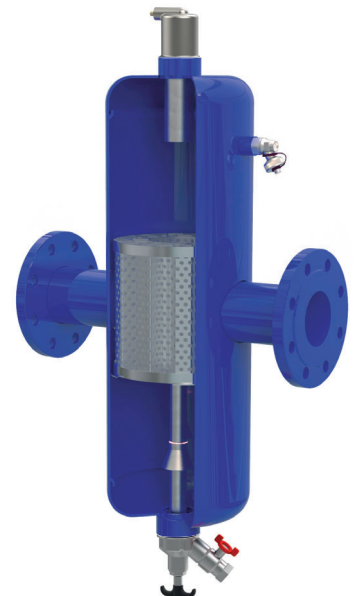

Where do air and dirt come from?

Air particles and gases are always present in the water of heating and cooling systems. They are generally a consequence of activities performed (maintenance, draining and filling, etc.), micro-leaks, diffusion, and chemical processes in the water. Dirt is caused by corrosion processes, maintenance of the system, or failing system parts. It can build up and cause blockages. The use of filters is not ideal as they do not trap smaller particles, silt up, cause high flow resistance, require regular maintenance, and replacement of components.



Installations

Viraplus is a combination of a deaerator and dirt separator that effectively removes circulating air and micro bubbles and dirt. In heating systems, the Viraplus should be in the flow and installed after the boiler. In chilled water systems, the unit must be located in the return pipe close to the chiller.

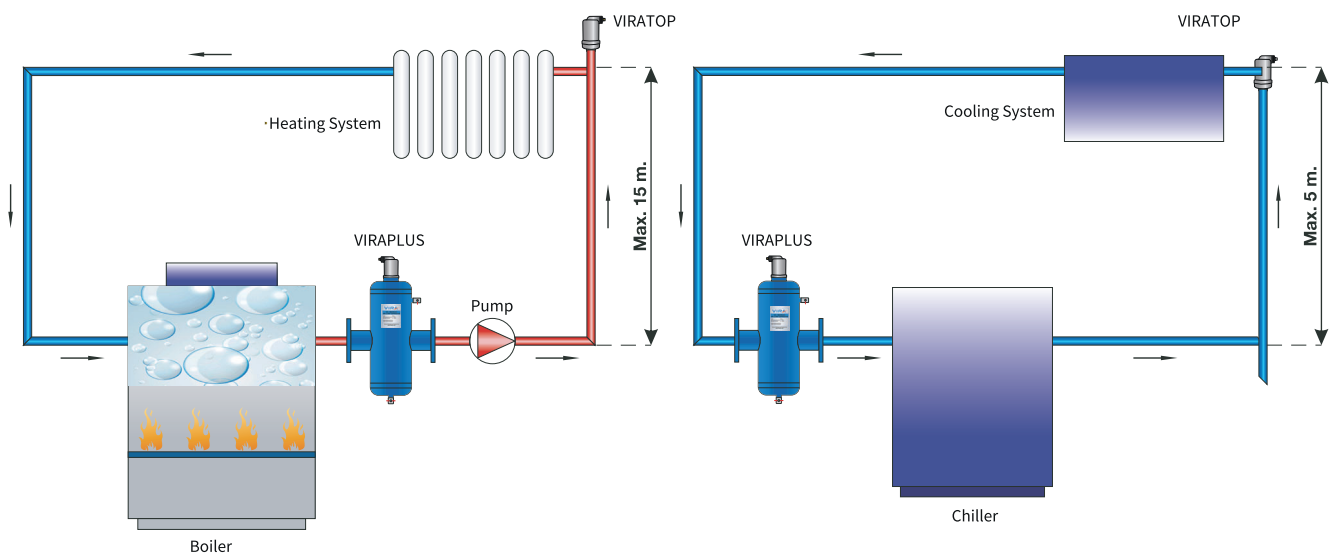

Air and Dirt-free System Water Through a Single Unit

Viraplus combined dirt and air separators can be used in place of individual deaerators and dirt separators. These combined units are highly efficient and extremely cost-effective and are becoming the preferred standard option throughout the industry. In heating systems, the units should be installed in the flow loop, situated immediately after the boiler and before the pump. In a chilled water system, the unit must be located in the return loop close to the chiller.

Solution

A system completely free of air and dirt is possible. There is a unique device whose combined action will remove all gases including dissolved air and dirt down to the smallest particle keeping the system free from air and dirt, permanently. It is maintenance-free as it works without strainers or filters. Less maintenance fewer costs.

Advantages

- Shortened system life due to corrosion.
- Reduced comfort due to less heat transfer and noises.
- Cavitation and magnetite damage pumps.
- Disruptions of the system.
- Loss of image for installers and component suppliers.
- Constant low-pressure drop
- Exceptional guarantee

Dimensions

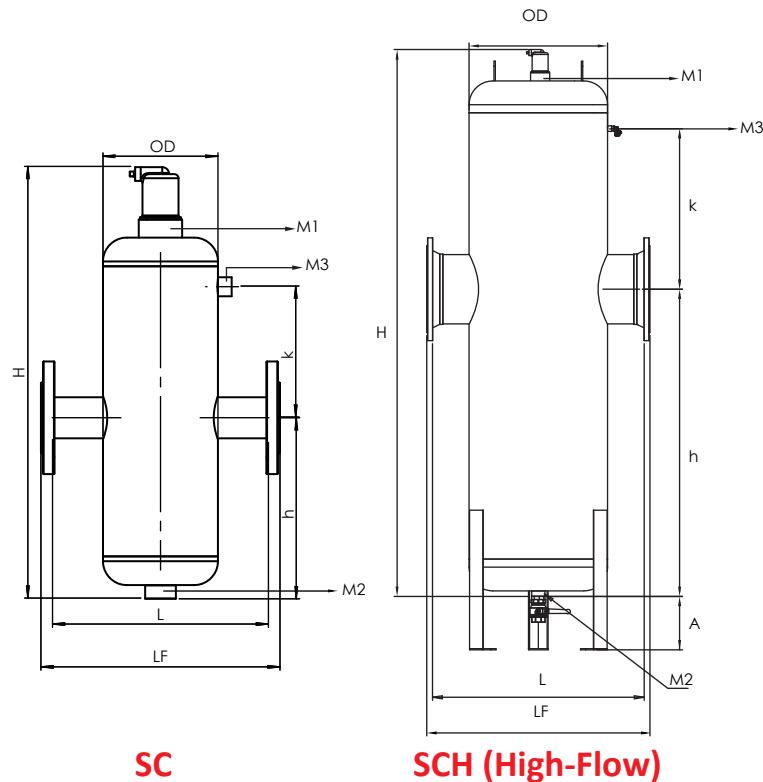

SC

SCH (High-Flow)

	Connection DN	OD (mm)	L (mm)	LF (mm)	H (mm)	h (mm)	Standart; Nom. 1,5 m/s				Hi-flow; nom. 3 m/s				M1	M2	M3		
							nom. = 1,5 m/s				max. = 3 m/s								
							Max.Flow (L/s)	Max.Flow (m3/h)	Max.Flow (kPa)	Leg A (mm)	H (mm)	h (mm)	Max.Flow (L/s)	Max.Flow (m3/h)	Max.Flow (kPa)	Leg A (mm)			
SC	50	168,3	330	350	632	265	3,3	12	3		880	370	5,8	21	11,8		1 3/4"	½"HM	1"
SC	65	168,3	330	350	632	265	6,3	22,5	2,7		880	370	10,0	36	11,6		1 3/4"	½"HM	1"
SC	80	219,1	450	470	791	345	8,3	30	2,9		1110	480	15,0	54	12,4		1 3/4"	½"HM	1"
SC	100	219,1	455	475	791	345	12,5	45	3,7		1110	480	23,3	84	14,6		1 3/4"	½"HM	1"
SC	125	323,9	615	635	1064	480	20,8	75	4,2		1540	700	36,7	132	16,8		1 3/4"	½"HM	1"
SC	150	323,9	615	635	1064	480	31,3	112,5	4,9		1540	700	52,8	190	19,4		1 3/4"	½"HM	1"
SC	200	400	745	775	1307	615	52,1	187,5	5,8		1960	920	94,2	339	23,1		1 3/4"	½"HM	1"
SC	250	500	860	890	1578	815	83,3	300	6,9		2650	1250	146,9	529	27,7	270	1 3/4"	½"HM	2"
SC	300	600	975	1005	1902	1120	114,6	412,5	7,7		3160	1510	211,9	763	31	270	1 3/4"	½"HM	2"
SC	350	700	1098	1128	2709	1553	143,8	517,5		270	3570	1580	288,3	1038		270	1 3/4"	½"HM	2"
SC	400	800	1194	1226	3030	1691	188,3	678		270	3900	1790	376,7	1356		270	1 3/4"	½"HM	2"
SC	450	900	1300	1330	3334	1877	238,3	858		270	4330	2000	476,7	1716		270	1 3/4"	½"HM	2"
SC	500	1000	1400	1430	3641	2065	294,2	1059		270	4800	2230	588,6	2119		270	1 3/4"	½"HM	2"
SC	600	1200	1600	1630	4240	2438	423,8	1525,5		270	5690	2680	847,8	3052		270	1 3/4"	½"HM	2"

Operating pressure : 0 - 10 bar

Fluid Temperature : 0 - 110 C

VIRAFIX

Description

A good hydraulic balance is highly important for HVAC and process systems with separated circuits or several groups and pumps. The effective removal of air and dirt also ensures water heating systems perform at their best. Hydraulic balancing and air and dirt separation are combined in the ViraFix.

The combination of three functions in one, not only helps you reduce costs and increase your water heating system's energy efficiency but also saves on space, installation, and maintenance costs. The ViraFix can be used for both new builds, refurbishment, and projects for refurbishing heating, cooling, and process systems, and improving energy efficiency.



SCX-F



SCX-F-M

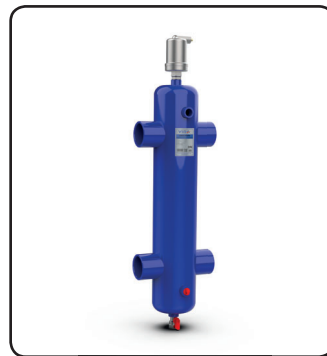

SCX-D-M



SCX-D-M -T

Features

Body	: Carbon Steel - ST37/Nickel Coated
Size	: DN 50-600
Max. Work.Temp.	: 110 °C
Max. Work. Pressure	: 10 Bar
Product Code	: SCX

Benefits

- Three functions in a single component
- Just four connections instead of eight
- Optimum hydraulic balance between primary and secondary pumps
- Viratube guarantees minimal fluid mixing and thus the best temperature differential
- Real, active deaeration and dirt separation
- Constant low pressure drop
- Even the tiniest air bubbles and dirt particles are separated and remove
- Compact design and limited built-in height, thanks to the Viratube
- Exceptional guarantee

Installations

Installation of a hydraulic separator in a heating system provides proper mixing when the flow in the boiler circuit is different from the flow in the distribution circuit. Also, Virafix is a combination of a deaerator, dirt separator, and hydraulic separator which removes circulating air and micro bubbles also dirt effectively.

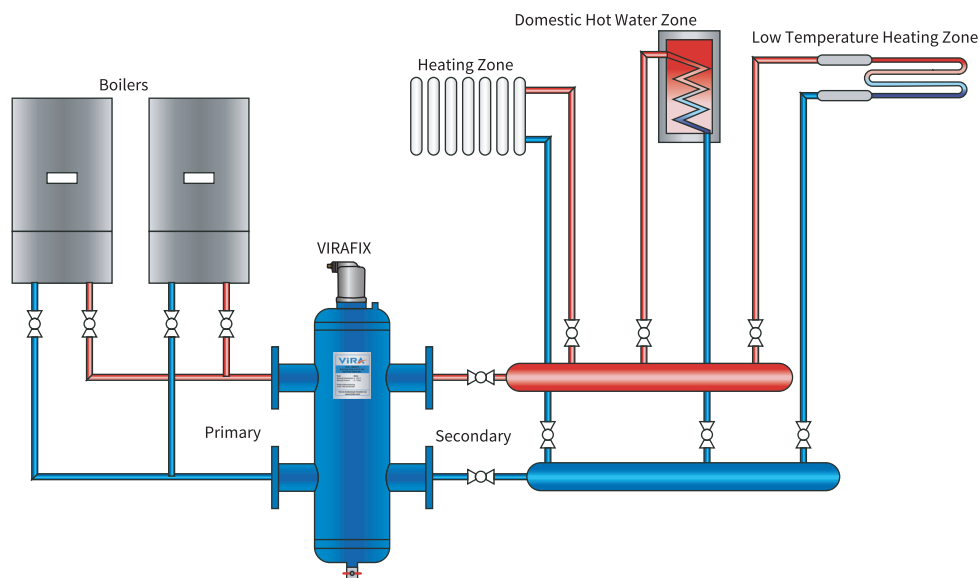

Dimensions

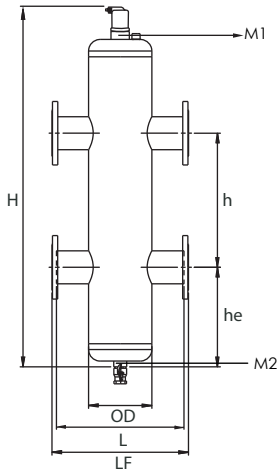

SCX-F

		Standart; Nom. 1,5 m/s												
		Nom. = 1,5 m/s												
	Connection DN	Connection OD (mm)	L (mm)	LF (mm)	H (mm)	h (mm)	he (mm)	Max. Flow (L/s)	Max. Flow m ³ /h	Max. Flow (kPa)	Flanged Weight	Welded Weight	ΔT=15°C kw	ΔT=6°C kw
SCX	50	168,3	330	350	812	248	240	3,3	12	3	25	17	218	87
SCX	55	168,3	330	350	927	273	305	6,3	22,5	2,7	36	28	349	140
SCX	80	219,1	450	470	982	273	360	8,3	30	2,9	46	33	471	188
SCX	100	219,1	455	475	1232	345	465	12,5	45	3,7	56	38	820	328
SCX	125	323,9	615	635	1532	448	560	20,8	75	4,2	94	77	1256	502
SCX	150	323,9	615	635	1832	543	670	31,3	112,5	4,9	106	48	1884	753
SCX	200	400	745	775	2336	695	870	52,1	187,5	5,8	158	117	3143	1256
SCX	250	500	860	890	2886	860	1100	83,3	300	6,9	297	216	5023	2009
SCX	300	600	975	1005	3402	1020	1296	114,6	412	7,7	390	310	764	2826
SCX	350	700	1098	1128	3970	1130	1420	143,8	517,5		490	400		
SCX	400	800	1194	1226	4470	1280	1620	188,3	678		570	460		
SCX	450	900	1300	1330	4860	1365	1830	238,3	858		660	520		
SCX	500	1000	1400	1430	5400	1540	2030	294,2	1059		890	715		
SCX	600	1200	1600	1630	6395	1825	2445	423,8	1525,5		1080	890		

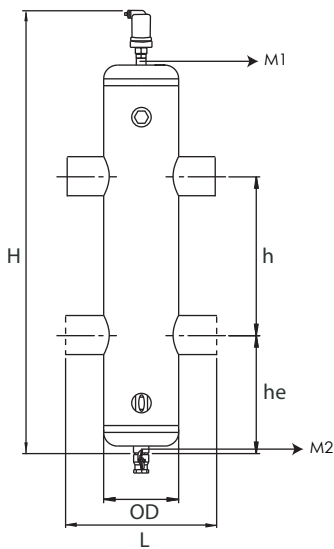

SCX-D-M

	Connection	Connection OD (mm)	H (mm)	L (mm)	h (mm)	he (inch)	Weights (kg)	Max. Flow (L/s)	Max. Flow (m ³ /h)
SCX-D-M	1"	168,3	811,5	330	247,5	240	1,053	0,56	2,00
SCX-D-M	1-1/4"	168,3	926,5	330	272,5	305	1,015	1,00	3,6
SCX-D-M	1-1/2"	219,1	981,5	450	272,5	360	1,260	1,39	5,0
SCX-D-M	2"	219,1	1231	455	345,1	464,8	4,41	1,94	7,0

VIRABALANCE

Description

VIRABALANCE Hydraulic Balance Tanks are compact economical units that allow fast and efficient installation of primary/secondary piping for many different boiler systems. When more than one boiler is used at the primary loop, more than one pump will run and create abnormal variations in circuit flow rates and pressures. A hydraulic balance Tank is installed between the primary and secondary loops and eliminates the need for an additional pump to circulate fluid through the primary loop. Thereby boilers and the heating circuits can have the proper flow rate independently.



SB-F



SB-D

Features

Body	: Carbon Steel - ST37 / Nickel Coated
Size	: DN 50 - 600
Max. Work.Temp.	: 110 °C
Max. Work. Pressure	: 10 Bar
Product Code	: SB

Benefits

- The flow over the boiler is constant
- More than one boiler application hydraulic balance is provided
- Water flow rate can be adjusted in the system
- Separates the primary and secondary circuit
- Balances the pressure difference between the hot water line and cold water line

Installations

Installation of a hydraulic balance tank in a heating system provides proper mixing when flow in the boiler circuit from flow in the distribution circuit.

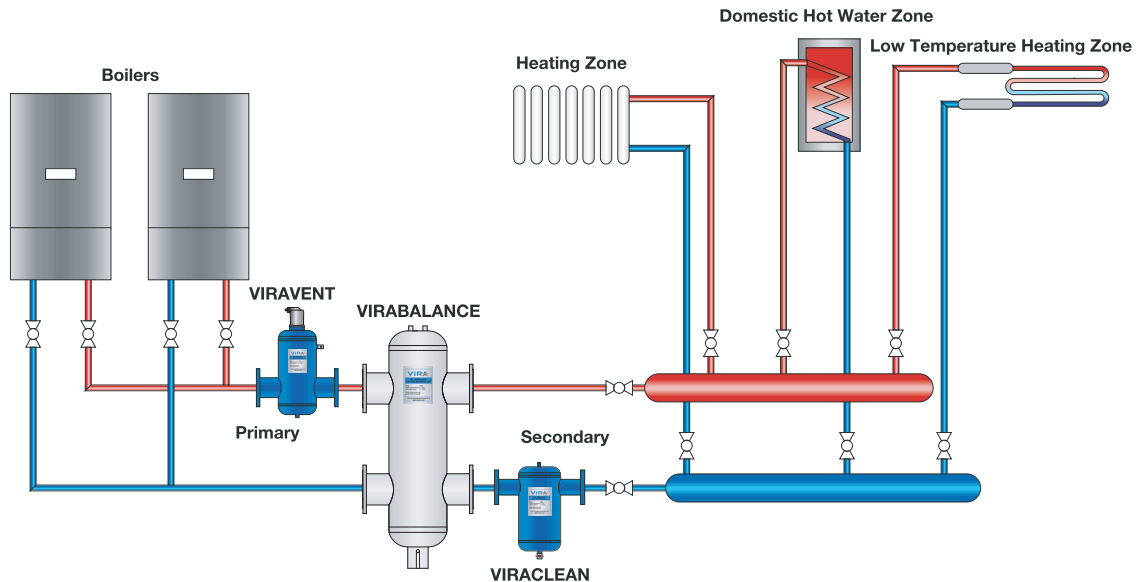

Balance Tank Selection

- When sizing, the max. The heating water flow rate should be taken as a basis.
- Water flow in the hydraulic balance tank max. Dimensioning should be done at 0.2 m/s.
- The pump on the primary side must be selected to overcome the resistances of the boiler and the primary side installation. The pump on the secondary side must be selected to overcome the resistance of the secondary side installation. All heating circuits on the secondary side must have a separate pump. The resistance of the balance tank is at negligible levels.
- The low temperature is measured by the flow temperature sensor in a welded sensor sleeve near the secondary side flow over the hydraulic balance tank.

The Difference Between ViraBalance and ViraFix

- ViraBalance has holed metal steel inside.
- Provided without air vent and drain valve.
- ViraFix has stainless steel filters in primary and secondary lines.
- Contains an automatic air vent.
- The magnetic filtering option is available.

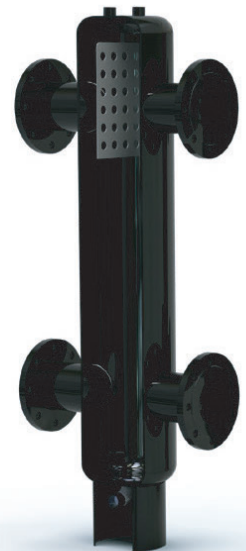

Dimensions

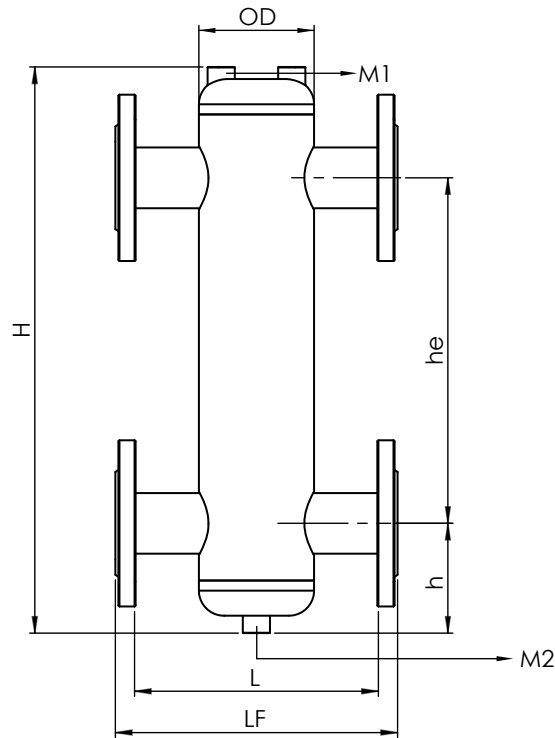

SB

Standart; nom. 1,5 m/s

nom. = 1,5 m/s

	Connection DN	OD (mm)	L (mm)	LF (mm)	H (mm)	h (mm)	he (mm)	Max.Flow (L/s)	Max.Flow (m3/h)	Max.Flow (kPa)	Flanged Weight	Welded Weight	M1	M2
SB	50	114,3	260	280	562	109	343	3,3	12	3	10	10	1/2"	1"
SB	65	168,3	330	350	862	179	505	6,3	22,5	2,7	30	18	1/2"	1"
SB	80	219,1	450	470	1242	357	657	8,3	30	2,9	43	30	1/2"	1"
SB	100	219,1	455	475	1242	357	657	12,5	45	3,7	45	31	1/2"	1"
SB	125	323,9	615	635	1535	423	819	20,8	75	4,2	72	52	1/2"	1"
SB	150	323,9	615	635	1793	478	972	31,3	112,5	4,9	120	80	1/2"	1"
SB	200	400	745	775	2197	554	1219	52,1	187,5	5,9	210	150	1/2"	1"
SB	250	500	860	890	2694	650	1523	83,3	300	6,9	350	270	1/2"	2"
SB	300	600	975	1005	3300	900	1800	114,6	412,5	7,7	420	315	1/2"	2"
SB	350	700	1098	1128	3914	1000	2103	143,8	517,5		580	460	1/2"	2"
SB	400	800	1194	1226	4320	1100	2404	188,3	678		620	496	1/2"	2"
SB	450	900	1300	1330	4830	1200	2700	238,3	858		950	786	1/2"	2"
SB	500	1000	1400	1430	5330	1300	3000	294,2	1059		1350	1165	1/2"	2"
SB	600	1200	1600	1630	6300	1500	3600	423,8	1525,5		1800	1620	1/2"	2"

CUSTOMIZED MODELS / OEM PRODUCTIONS

Description

Below are the products manufactured in the models specified by our customers. Vira can manufacture these models or according to the drawings you send us.



Tangential Air Separators

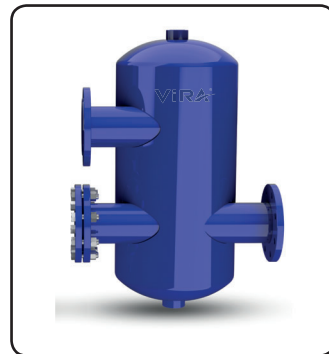

Description

Designed to minimize heat loss from Vira separators and to prevent potential industrial accidents in the area of operation. They are the most commonly used jacket type with the shortest payback period. Virajac jackets are fully removable and can be used in heating and cooling systems.



Benefits

- Energy Saving
- Improves workplace safety and comfort
- Easy to service and remove
- Water-resistant
- Suitable for retrospective installation
- Low density and low thermal conductivity
- Resilience and resistance to thermal shock
- Flexible and easy to install
- Excellent obstructing voice and mechanism strength

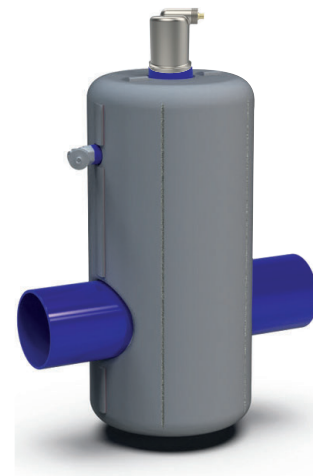

Layers of Virajac Insulation Jackets

- Silicone-coated glass fiber fabric
- Polyurethane-coated glass fiber fabric
- Aluminium-coated glass fiber fabric as insulation material
- Elastomeric rubber foam in cold lines
- Rock wool and glass wool in warm and hot lines



Technical Details

- Touch Temperature (Exterior): $< 45^{\circ}\text{C}$
- Classification Temperature: 260°C
- Working Temperature: 230°C
- Density: 140 kg/m^3
- Color: Gray

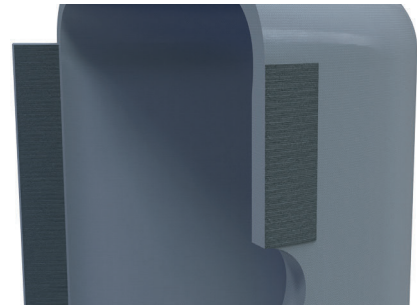

CHEMICAL DOSING POT

Description

Chemical Dosing Pots allow you to add chemicals such as corrosion inhibitors, cleaning agents, and Glycol antifreeze rapidly into a closed heating or chilled water system. Chemical dosing pots should be sized in accordance with the size of the system. We offer Stainless Steel and Carbon Steel dosing pots that have a capacity from 5 liters up to 50 liters.

These carbon steel and stainless steel chemical dosing pots are ideally placed across the main flow and return pipework with the flow from the bottom of the pot and the return at the top. This will create the ideal conditions for the rapid intake of chemicals.



If a modern system is dosed correctly it

- Increases efficiency
- Reduces energy costs
- Drops CO2 Output
- Improves the life cycle of the system

Benefits

- It is ergonomic.
- It is convenient for use in different climate conditions.
- It is convenient for operating in parallel with the solar energy systems and heater boilers.
- It produces hot water at high capacities in narrow volumes.
- It can be used as natural circulation or with a circulation pump.

Sizing

The size of the dosing pot installed in a system is not critical as multiple doses of chemicals can be put into the system to reach the correct concentration. The benefits of using a smaller unit are that it is easier to physically handle and also allows for more accurate dosing. However, the time on site for performing multiple doses has to be considered; this factor should influence your decision when selecting dosing pots.

Note: Chilled water systems often require large volumes of glycol to be dosed into the system; a larger dosing pot may be required for chilled water systems.

The formula below can be used as a guide to help you in your selection:

Boiler Power (kW) x 12 liters/kW x 0.01 (based on 1% concentration*) = Volume of chemical required

Example: Boiler Power 250kW x 12kW x 0.01 = 30 liters of chemical

You could may of the following dosing pots for this installation

- 5 liter - dose 6 times
- 10 liter - dose 3 times
- 15 liter - dose 2 times

Confirm the required concentration level for the chemical being used.



<p>To ensure a fast, but safe dispersal of chemical dose, it is important that the unit is installed correctly.</p> <p>Install the unit between the flow and return pipework at the point with the highest differential pressure.</p> <p>Ensure the unit is securely fixed to a wall using the integral wall mounting brackets.</p> <p>Make certain that the drainage point is either piped to waste or that there is suitable space beneath the unit for the collection of discharged fluid.</p>	<p>For correct operation of the unit follow the instructions and diagram below. Where multiple dosing is required, repeat the steps as necessary until the correct system concentration is achieved.</p> <p>*ISOLATE THE UNIT Close all Valves</p> <p>*DRAIN THE UNIT Open the drain valve first, followed by the fill valve.</p> <p>*FILL THE UNIT Close the drain valve and pour the dosing chemical into the unit through the tundish.</p> <p>*BEGIN DOSING Fully open the inlet and outlet valves slowly.</p> <p>*COMPLETE DOSING Close all valves when dosing has been completed.</p> <p>Repeat the above steps if necessary.</p>
---	---

Dimensions

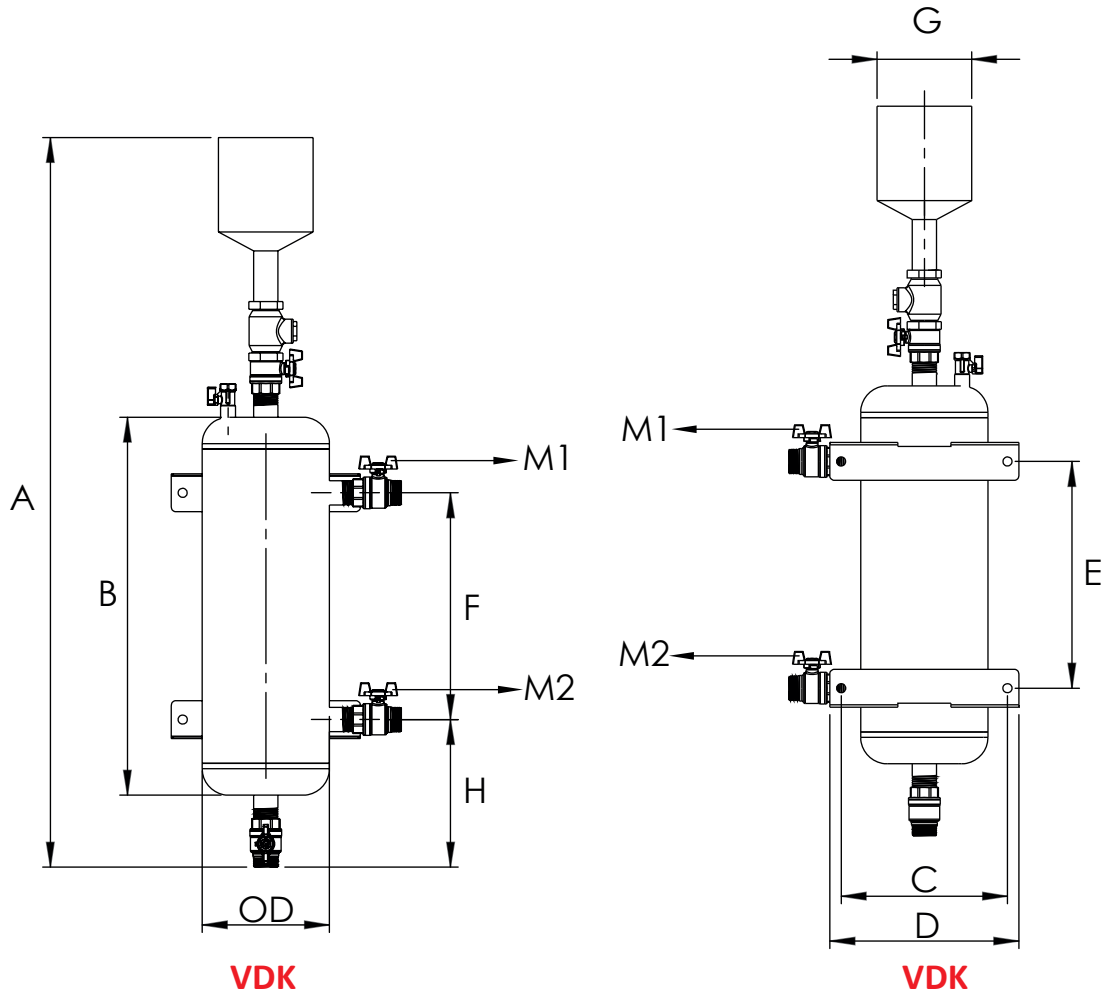

VDK

VDK

DIMENSIONS (mm)

	CAPACITY (lt)	Connection OD (mm)	A (mm)	B (mm)	C (mm)	D (mm)	E (mm)	F (mm)	G (mm)	H (mm)	M1	M2
VDK	5	168,3	847,9	324	220	250	180	180	125	168	1"	1"
VDK	10	168,3	965,5	500	220	250	300	300	125	195	1"	1"
VDK	15	219,1	923,9	450	350	400	250	250	125	195	1"	1"
VDK	20	219,1	1073,9	600	350	400	400	400	125	195	1"	1"
VDK	25	219,1	1173,9	700	350	400	500	500	125	195	1"	1"
VDK	35	273,1	1125,9	652	400	450	392	392	125	225	1"	1"
VDK	50	323,9	1279,2	800	450	500	550	550	125	221	1"	1"

FULL FLOW MAGNETIC FILTER

Description

This manual contains information on safety, installation and maintenance.

To maintain optimum efficiency, annual cleaning is recommended.

- Isolate the heating system and close both the two isolating valves. Prepare a suitable bucket to collect spillage.
- Unscrew the knurled moulding and withdraw the magnetic bar.



 The magnetic bar is a very powerful 9000 gauss magnet. Keep away from personnel with heart pacemakers, any sensitive electronic devices storage media or magnetic bank cards.

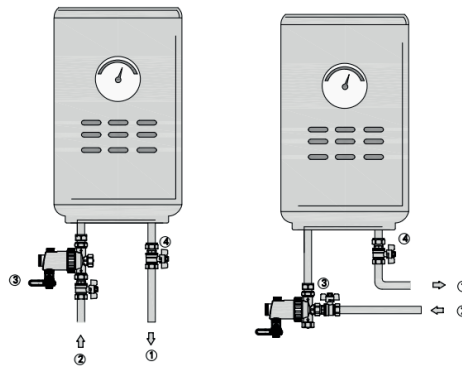

Installation instructions

The filter may only be installed by a qualified person, such as a qualified service technician or plumber.

- Find a suitable location for the filter that will allow sufficient access for service (maintenance). We recommend using a return pipe, but do not place the filter between the boiler and the overflow pipe in systems with an open expansion tank.
- Drain and depressurize the heating system.
- Mark the pipe with a suitable tool, so that you can cut out the marked part and then deburr.
- Install shut-off ball valves on the supply and return pipes.
- Fit the magnetic filter. Make sure the direction of the arrow follows the flow of the heating system. Use flat washers and fully tighten the union nuts on the valves to ensure a watertight seal.
- Open the shut-off valves and switch on the heating system.
- Bleed air as needed using the air vent valve.

Features

Filter type	: AFM-10B PLUS
Connecting screws	: 3/4"
Max. magnetic induction	: 12,000 Gauss
Filter volume	: 120 ml
Maximum temperature	: 120 °C
Maximum pressure	: 12 bars
Maximum flow 1Kpa (l/m)	: 15l
Maximum absorption capacity	: 155 g
Strainer density	: 300 µm
Magnet diameter	: 14.5 mm
Mass	: 596 g (without valves)
Dimensions	: 147mm x 120mm

MAGNETIC FILTER

Description

Harmful effects to boiler system caused by ferrous particles

- Sludge due to accumulation and corrosion of ferrous particles is easy to affect heat conduction of the boiler, reducing the heating efficiency and causing more energy consumption.
- The heat blocked by the corrosive dirt escalates the temperature of the chamber, abnormal temperature overheats the metal components, which is likely to incur damage or even explosion.
- Sludge also affect pipeline system, causing blocking and reducing water flow, in extreme cases, serious blocking may trigger pipe burst.
- Chronically accumulated dirt exerts a negative influence on the operation life of the boiler, removing the dirt is a difficult task and requires extra maintenance cost and time.



Water flow direction

- Water inflow through the redirector then enters the middle part of the magnetic filter, ferrous particles are then drawn by the magnetic rod, non-ferrous particles will be filtered by stain-less steel mesh. Filtered water will flow along with the interior wall and finally flow out of the magnetic filter.

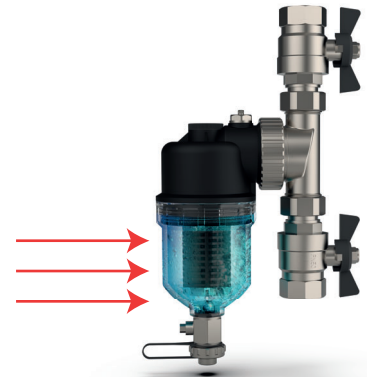

Why You Need the Magnet Filter from Avonflow?

- Owing double sealing at every connection point.
- Having highest magnet power 12000GS.
- With air vent, to ensure stable air pressure.
- Universal diverter can freely rotate to decide orientation.
- With free spanner, easily to unscrew the tank, the valve and diverter.
- With drain-off valve, so easily to be cleaned.

Features

Filter type	: Suitable for Heat Pump & Central Heating Systems
Max Flow Rate	: 6.9 M ³ /h
Filter Volume	: 530ml
Working Pressure	: 3 bar
Max. Pressure	: 12 bar
Max. Dynamic Pressure	: 1.5 bar
Max. temperature	: 120°C
Max. magnetic induction	: 12,000 gauss

VIRAconsole

Description

A complete product for hanging expansion vessels up to 25 liters attached to the water supply and to the wall. As the conventional Viraconsole but includes accessories.



Advantages

- Equipped with a wall plate with two slots for accurate wall mounting.

Technical Specifications

- Supplied with;
Viraconsole pressure gauge (0-4 bar) with shut off valve,
Viraconsole $\frac{3}{8}$ " floatvent with shut off valve, Safety valve $\frac{1}{2}$ " (set pressure: 3 bar), Viraconsole quick-release coupling, Fixing set.

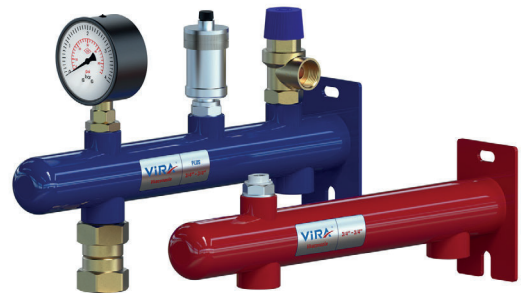

Description

Expansion vessels, also known as expansion tanks, can be found in most domestic pressurized heating systems. If you have a combi boiler, you will have an expansion vessel. This vessel contains air and water from the central heating system, and its purpose is to maintain the right level of pressure in the system.

There are various expansion tank designs, but the most common among modern boiler designs is the bladder-type system. This design consists of a cylinder or disc which is split into two parts by a thin rubber sheet known as a 'diaphragm'. One side is filled with water from the central heating system, while the other is filled with nitrogen. An expansion vessel also has an air valve that allows for the system to be depressurized and repressurized over time.

Where to install the expansion vessel?

It is likely that your expansion vessel is located inside the boiler casing. However, make sure to refer to your boiler manual to double-check this. If you are having trouble identifying the vessel or need advice on finding a replacement, speak to a qualified heating engineer.

What causes an expansion vessel to fail?

An expansion vessel can fail due to rust and subsequent water leakage, although this is unlikely in most modern sealed water heating systems. It is more common for the diaphragm to become thinner and perforate over time, causing the whole system to fail. The filling valve can also leak air and cause pressure failure if left unchecked.



Dimensions

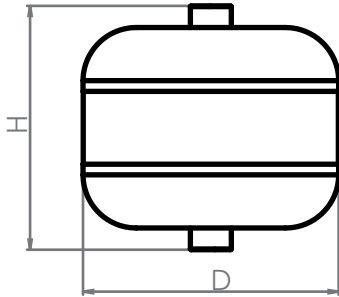

DIMENSIONS (mm)						
	CAPACITY (lt)	Pressure (Bar)	D (mm)	H (mm)	(INCH)	(Bar)
VEXT	8	10	219	305	3/4"	2
VEXT	12	10	219	365	3/4"	2
VEXT	19	10	280	405	3/4" - 1"	2
VEXT	24	10	280	471	3/4" - 1"	2
VEXT	24	10	350	471	3/4" - 1"	2
VEXT	35	10	380	500	3/4" - 1"	2
VEXT	50	10	380	615	3/4" - 1"	2

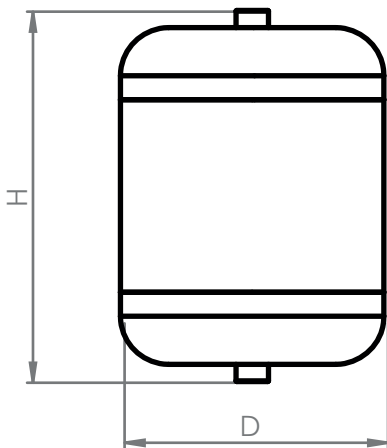

DIMENSIONS (mm)						
	CAPACITY (lt)	Pressure (Bar)	D (mm)	H (mm)	(INCH)	(Bar)
VEXT	2500	10-16-25	1200	2510	2"	4
VEXT	3000	10-16-25	1200	2760	3"	4
VEXT	4000	10-16-25	1500	3130	3"	4
VEXT	5000	10-16-25	1500	3660	3"	4
VEXT	6000	10-16-25	1600	3840	3"	4
VEXT	8000	10-16-25	1600	4840	3"	4
VEXT	10000	10-16-25	1600	5840	3"	4

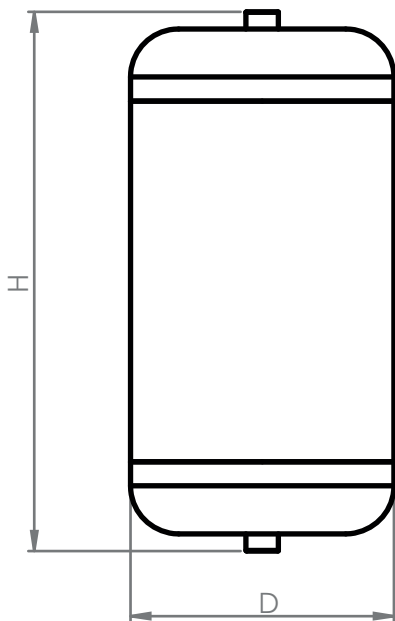

DIMENSIONS (mm)						
	CAPACITY (lt)	Pressure (Bar)	D (mm)	H (mm)	(INCH)	(Bar)
VEXT	35	6-15	380	470	1"	2
VEXT	50	6-15	380	620	1"	2
VEXT	60	6-15	380	720	1"	2
VEXT	80	6-15	425	740	1"	4
VEXT	100	6-15	460	775	1"	4
VEXT	150	6-15	508	940	1"	4
VEXT	200	6-15	585	965	11/4"	4
VEXT	300	6-15	635	1150	11/4"	4
VEXT	500	6-15	750	1450	11/4"	4

BUFFER-TANKS

Description

Buffer tank for storing heating and cooling water. The series of connectors (2014/EU/68) for heat generators and consumers are arranged opposite to each other as charging or discharging connectors. Between these series of connectors there also vertically arranged screw-in options for sensor sleeves, thermometers or similar (3 x Rp 1 1/2, 1 x Rp 1). In addition, there are two connections. Storage tank of steel S235JR+AR, inside uncoated and outside corrosion protected. Buffer tank up to 1000 litres insulated with 100mm, buffer tank > 1000 litre with 120 mm removable fleece insulation; according to DIN 4102-1 material class B2. Tank available in energy efficiency class . The heat losses are measured on an externally certified test bed.



Technical Specifications

Type	: Buffer Tank
Color	: Blue
Insulation	: -
Insulation Strength	: 120 mm
Energy efficiency class	: °C
Nominal capacity	: 14131
Operating temperature	: 95 °C
Operating pressure	: 10 bar
Connection	: (2014/EU/68)
Heat maintaining losses	: 167 W
Diameter	: 1240 mm
Height	: 2119 mm
Tilt dimension Approx.	: 2178 mm
Weight	: 212.27 kg

EXPANSION JOINT

Description

Metal expansion joints prevent damage to other components of the system by reducing the effect of changing lengths under the influence of heat. They are usually designed as metal structures containing one or more layers. This structure expands and contracts during heating, minimizing stress in the system



Madde

Cyclic Expansion Joints : These types of connections are generally used in systems with a specific direction and provide a cyclic structure to control expansion.

Rigid and Flexible Expansion Joints : Rigid connections provide more support, while flexible connections offer more mobility. Selection should be made according to the needs.

Welded and Nut Connections : Welded connections are generally more durable, but can be more complicated to install. Nut connections, on the other hand, provide easier assembly.

Application Areas

- Industrial Plants** : Widely used in chemical, oil and gas industries.
- Pipelines** : It provides flexibility in pipe systems where temperature changes are frequent.
- Ventilation Systems** : Manages expansion and contraction movements in HVAC systems

Advantages

- High Durability** : Metal expansion joints are resistant to high temperature and pressure.
- Flexibility** : Increases the safety of the system by providing flexibility against temperature changes.
- Long Life** : It offers long-term use with the right material selection.

MULTIZONE MANIFOLDS

Description

Compact manifolds are used in heating systems to allow different heat settings in the various rooms when there is only one heat generator.

The various configurations are compact and can be easily fitted in any kind of hydraulic circuit, with the advantages of ease of installation and saving of useful living space. The manifolds have pre- formed shell insulation to guarantee perfect thermal insulation.

The ViraFix is a complete unit which is installed between the boiler and the manifold. This contains an air separator and a dirt trap with a magnetite separator (to protect the heat emitter and circulation pumps) and can be delivered either with or without a hydraulic diverter.

The connections are designed to fit the manifold, ensuring easy installation.

Installer Benefits

- Planning/costing made simple thanks to the configuration of prefabricated modules to create complex systems
- Perfect system integration thanks to a comprehensive range of connectable accessories
- Short assembly times thanks to a high degree of prefabrication and matched components
- No unwanted heat transfer thanks to the thermal separation of flow and return lines
- Clean professional finish

Body	: Carbon Steel
Max. Work. Pressure	: 10 Bar
Max. Work.Temp.	: 5-110 °C
Medium	: Water, non-hazardous glycol
Main Connections	: Flanged/ Threaded/Victualic
Centre Distance	: 125 mm

Customization

- Vira, which is an expert manufacturer in filtration, can produce according to customer requests in all products it produces.



MANIFOLDS

Durability

Stainless steel is resistant to high temperatures and pressures, which makes it long-lasting.

Corrosion Resistance

It resists chemical substances and humid environments, making it particularly useful in water and other fluid systems.

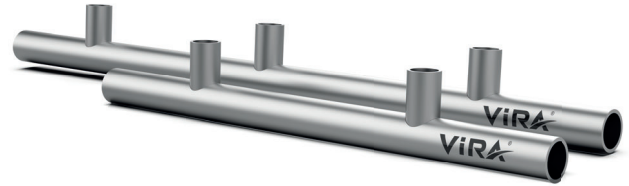

High Performance

It ensures effective heat transfer and proper distribution of fluids, which enhances energy efficiency.

Technical Features

- Pipes cold buckling
- Stainless steel AISI304 (AISI304 only on request)
- Made with TIG method without any additional material
- Degreasing / Electropolishing
- Working pressure: 20 bar
- Manufacturing of custom made
- Threaded collector: 1 1/4" - 4"
- Flanged collector: 2" - 10"
- Threaded ends: ISO 228 gas
- Flanges: UNI 2278 press flange
- Flanges: DIN2642 collar flange

SIZING

This selection can be used for heating and cooling systems.

For optimum results, a flow velocity should be less than 1,5 m/s. Above 1,5 m/s flow velocities will affect the Smartvent deaerators and dirt separators' ability to eliminate air. Two examples of different installation place possibilities:

A) If the installation place is low pressure and high temperature, the velocity should be 1,5 m/s.

1. From the 'Flow' axis at 70 m³/h at point A, move vertically to the 1,5 m/s water velocity curve at point B.
2. Move left from point B to meet the "Smartvent Dimension" axis at point D.
3. Always choose the dimension that is the nearest above the endpoint on the axis, for this example choose DN125.

B) If the installation place is high pressure and high temperature, the velocity should be 1 m/s.

1. From the 'Flow' axis at 70 m³/h at point A, move vertically to the 1 m/s water velocity curve at point C.
2. Move left from point C to meet the "Smartvent Dimension" axis at point E.
3. Always choose the dimension that is the nearest above the endpoint on the axis, for this example choose DN150.

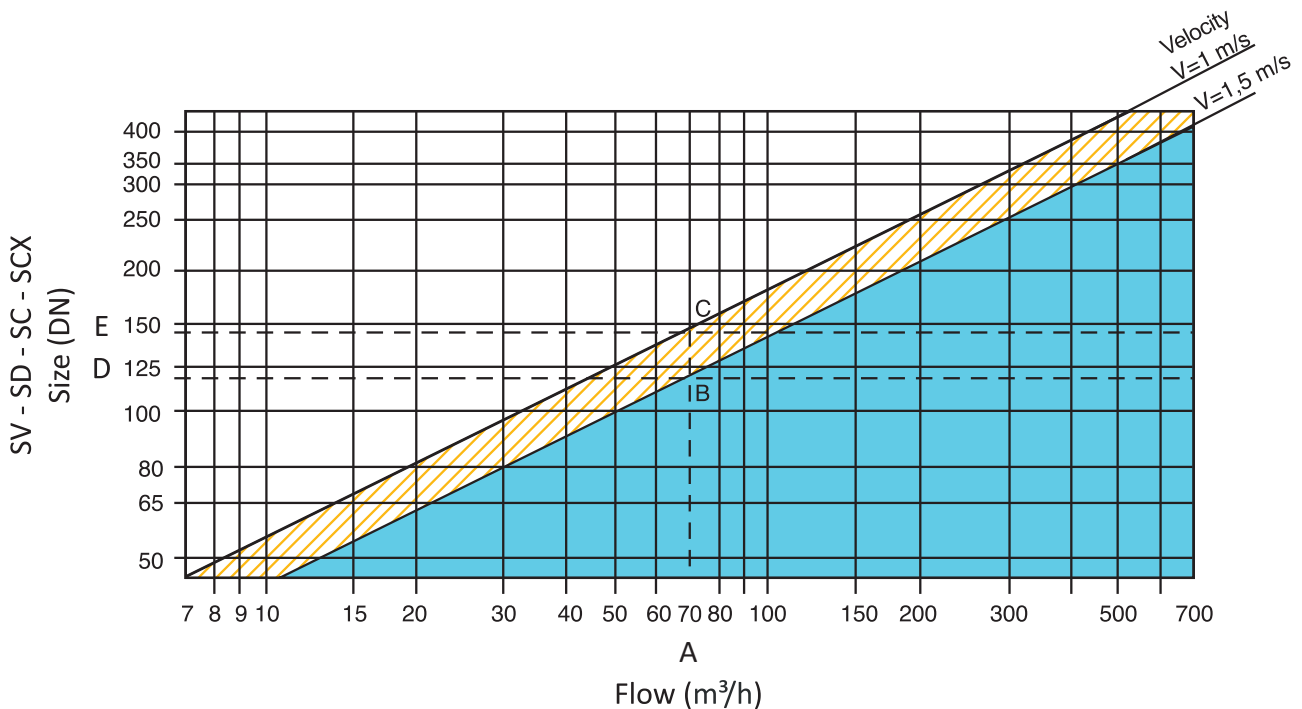

PRESSURE DROP

Resistance graphs to flow various diameters of Smartvent Air and Dirt Separator as below.

PRESSURE DROP CHART

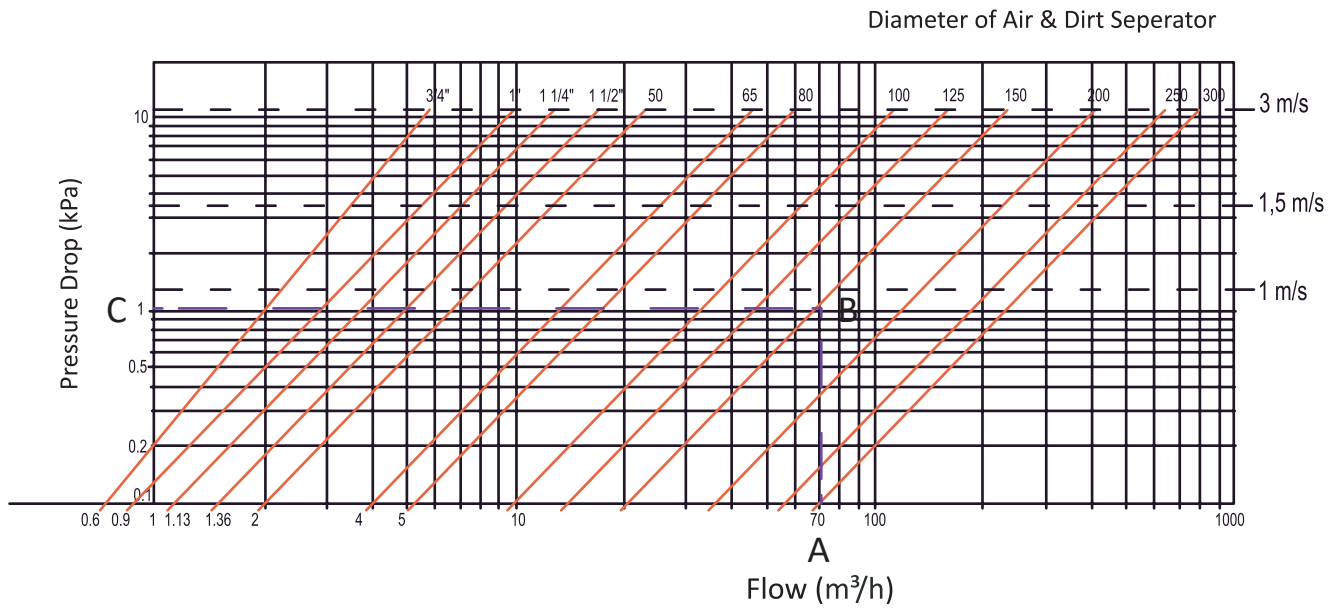

Example:

When the water flow is 70 m³/h pressure drop for the DN 150 Smartvent Air and Dirt Separators:

1. From the 'Flow' axis at 70 m³/h at point A, move vertically to the "Smartvent Dimension" DN 150 curve at point B.
2. Move left from point B to meet the "Pressure Drop" axis at point C, for this example, Pressure Drop will be 1 kPa.

NOTES

A series of horizontal dotted lines for writing notes, spanning the width of the page.

NOTES

A series of horizontal dotted lines spanning the width of the page, intended for taking notes.



Vira Products Provide Solutions to The Problems.

Vira is a young, dynamic and expert company in the production of separators, valves and steam-related products. To meet our customer's needs, we offer customers a combination of our application experience, ongoing technical support, correct installation, and commissioning ability with our high-quality products.

Vira provides durable, high-quality valves and steam-related products that are used in many kinds of applications, from unique custom jobs to large-scale installations.

- Automatic Air Vent
- Solar Automatic Air Vent
- Deaerators
- Dirt Separators
- Hydraulic Balance Tanks
- Expansion Joints
- Safety Valves
- Actuators
- Steam Separators
- Condensate Pump
- Sample Coolers
- Steam Boiler Automation
- Automatic Blowdown System
- Steam Flow Meters
- Steam Traps



Metal İş Sanayi Sitesi 11. Blok
No:37/39 İkitelli - İstanbul / Turkey

info@viraisi.com
www.viraisi.com

Tel :+90 212 549 57 70 (Pbx)
Fax : +90 212 549 58 48

