



Scope of Delivery

- i. ViraDeg
- ii. User Manuel
- iii. Flex Hoses
- iv. Quick Setting Sheet
- v. Build-Up Kit

Warning!



- In case of doubt, always contact the supplier
- In case of a heavily contaminated system fluid, install a dirt separator or filter in the main return line of installation

This booklet is designed for unpacking, commissioning and troubleshooting of ViraDeg model Vacuum Degassers manufactured by Vira Isı ve Endüstriyel A.Ş.

The required technical details can be found in the user manual that comes with the product in the box or on our website www.viraisi.com.

Vira Isı ve Endüstriyel Ürünler A.Ş reserves the right to change these terms and conditions at any time without prior notice. In the event that any changes are made, the revised terms and conditions shall be posted on this website immediately.

Unpacking

- i- Loosen the screws and remove the cover in the arrow direction.



- ii- After removing cover, degasser will be seen in horizontal position.



- iii- To be able to remove degasser out of box, loosen the bolts at the bottom.



- iv- Remove the degasser out of the box carefully in the arrow direction.

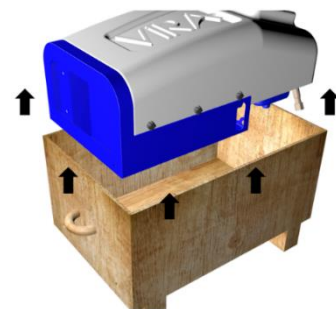

- v- Use hand grips on both sides, while carrying the degasser in vertical position.



Assembly

i- Flex Hoses Mounting

The units are connected to the installation by Flex hoses. There must be one meter horizontal distance between the inlet and outlet line. The units with refill feature have the third Flex hose connection. Only for V4-R Model this third flex hose is supplied in the box. For other models all hoses is supplied connected to the unit.

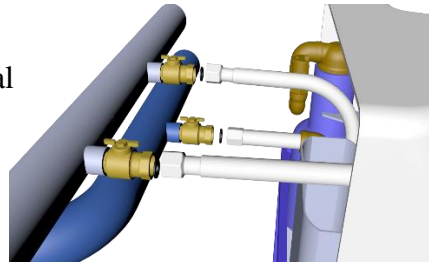

ii- Wall Mounting

V4 Model degasser frame to hang the wall wall-mounted external handles. To hang the V6 and V9 model units on the wall use the holes on the back side.

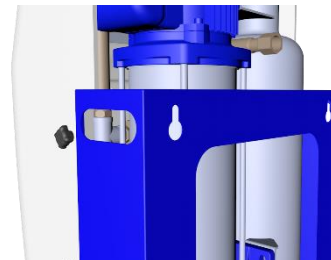

iii- Floor Standing

If the unit is used as floor standing, use threaded legs supplied with the unit.

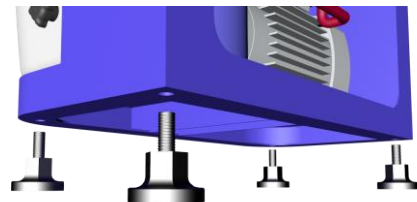

iv- Gaskets

Use gaskets supplied with the unit While making flex hose connections.

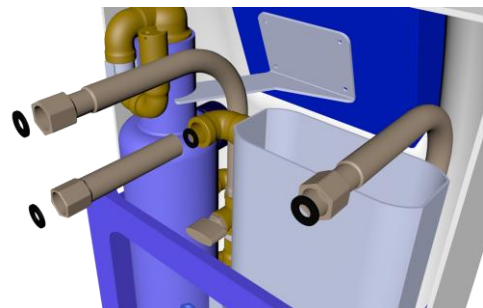

Commissioning

1. Degasser inlet hose is connected to the installation. The outlet hose is left open to the atmosphere to discharge air in the degasser.
2. The inlet valve is turned to the closed position.
3. The energy connection of the degasser is made and the system is energized.
4. By pressing the MENU button on the controller to make the necessary settings in accordance with the installation.
 - Max. Pressure
 - Refill Min. Pressure
 - Refill Max. Pressure
 - Max, Min Temperature
 - Working Hours
 - Language etc.
5. The MENU function is accessed by pressing the ENTER button and the TEST function is started.

Input Solenoid Valve is opened by pressing Down Arrow button and switching "Int OFF" (Internal OFF) to "Int ON"

The inlet valve is slowly opened to fill the degasser with water in a controlled matter. The water filling process is continued until there is no air remaining in the degasser (until some water flows from the degasser outlet hose (4)).
6. Press down arrow button on controller again and make INT-OFF to close the input solenoid valve.
7. Degasser outlet line is connected to the system and exit valve is opened.
8. Press MENU to SYSTEM ON / OFF and select "SYSTEM ON.
9. Press the MENU (ESC) button to exit the MENU and start the degasser.

Note: In V9 models, the system can also be vented using the air vents on the vacuum tube and on the pump. In the first filling phase, when the inlet and outlet hoses are connected, air vents points on the pump and vacuum tube must be open and after the water comes out of the valves, they must be closed.

Troubleshooting

1.1 Insufficient Water

- i- System pressure must be 1 bar. There may not be enough pressure.
- ii- The inlet valve may be closed. It should be turned on.
- iii- Check the solenoid valve connections. If the solenoid valve is defective, it must be replaced.
- iv- Pressure switch and connections on the tube body should be checked.

1.2 Sensor Error

The Grundfos RPS sensor may be faulty or disconnected. Check connections, replace sensor if faulty. (For temporary operation of the device until the sensor is supplied, the service settings must be set; Press Sensor and Temperature_Sensor must be 'OFF')

1.3 No Water

- i- Water inlet valve and water inlet solenoid valve must be checked.
- ii- S.ValveOfftime (Select): The solenoid valve may have a high shutdown time. Water may not remain in the tube due to vacuum. The shutdown time should be shortened.

1.4 High Temperature

The installation temperature has exceeded the set maximum value.

1.5 Low Temperature

The installation temperature has fallen below the set minimum value.

1.6 High Pressure

The installation pressure has exceeded the set maximum value.

- i- Check whether the degasser water outlet valve is open. Make sure it is not closed.
- ii- Check the installation pressure. If the system pressure is normal, from the SETTINGS menu, 'PressureMaxSet' value should be set 2-3 bars above the installation pressure.

1.7 Low Pressure

The installation pressure has fallen below the set minimum value.

1.8 MaxRefillingNumber

The degasser has performed more refills than allowed to reach the set refill_max_pressure value. There may be water leakage in the installation. If

the set value is insufficient, 'RefillingMaxNumber' value should be increased from the menu.

1.9 Many Time Refilling

More refills were performed in 12 hours than allowed. There may be water leakage in the installation. It should be checked.

1.10 No Refill Water

Refill container should be filled with water.

1.11 Standby

Since there is no air in the system, the degasser stops automatically. After 12 hours, it works again and checks the air of the installation. It discharges the air in the installation and switches to standby. If the device remains in standby mode: 'TotalAirvent' from the 'RunningLogs' menü must be checked and the number of purged air must be monitored. If the number of air purge does not increase by more than 10 in every 12 hours, the air sensor and its connections must be checked.

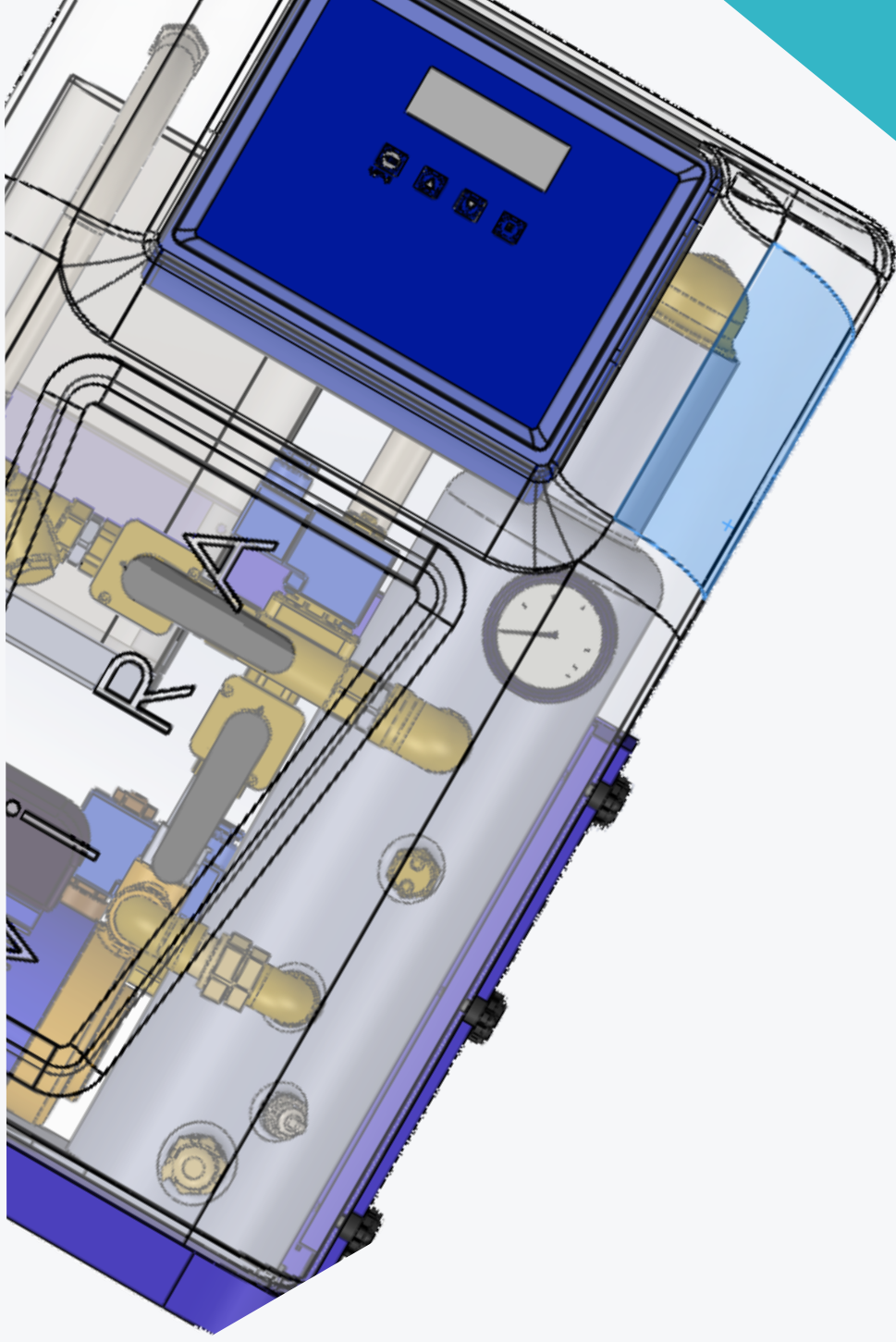

Vira Isı ve Endüstriyel Ürünler A.Ş.

ViraDeg producer

Address ; Ikitelli OSB, Metal İş Sanayi
11. Blok No.37-39 / Basaksehir / Istanbul

Phone : +90 212 549 57 70

Web : www.viraisi.com
